

SLOTTED BARREL HOODS

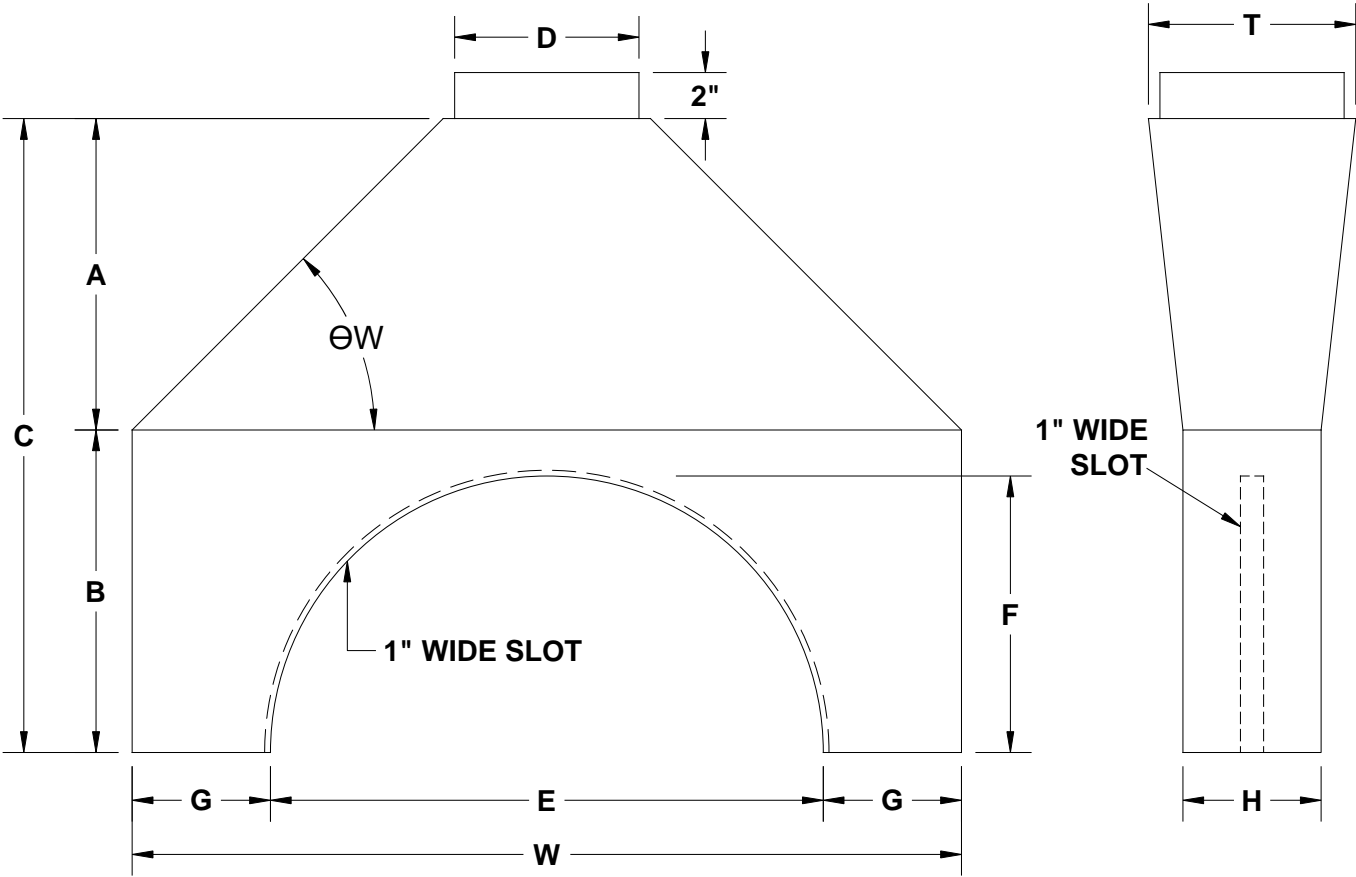

CONSTRUCTION: All welded 18 GA. galvanized steel, 304 or 316 stainless steel with 2B finish or #3 ground and polished and .063 aluminum mill finish. Heavier gauges available: 16, 14, 12 and 10.
DIMENSIONS: As required for job conditions.

Qty.	Material	Gauge	W	H	A	B	C	ΘW	Nominal D	Actual O.D./I.D.
E	F	G	T	Finish			Options			Tag

To maintain KEES' policy of continuous product development, we reserve the right to change prices, specifications, ratings and dimensions without notice or obligation.

Project		Location			
Engineer			KEES INCORPORATED 400 S. Industrial Dr. Elkhart Lake, WI 53020 Phone: (920) 876-3391 Fax: (920) 876-3065 Website: www.kees.com		
Architect				Dwg. No.	SD-SSBH
Contractor				Date	06/17

SLOTTED BARREL HOODS

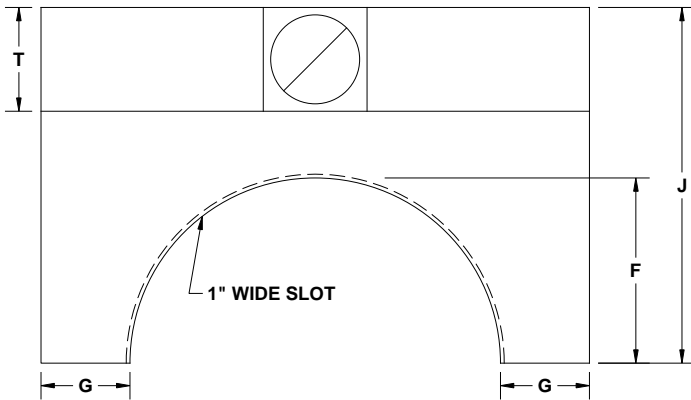

PLAN VIEW

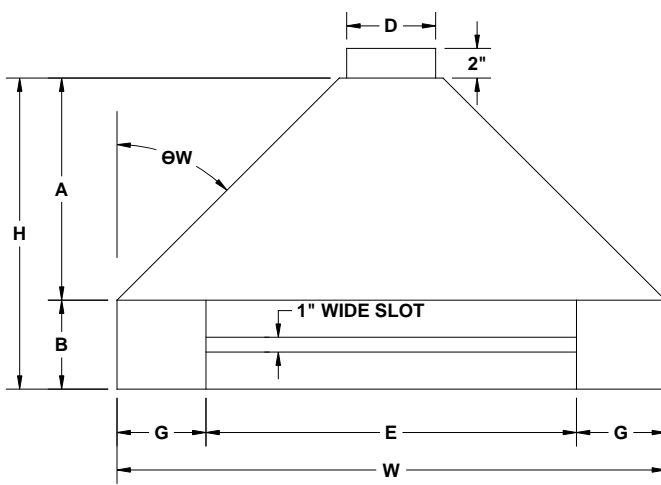

ELEVATION VIEW

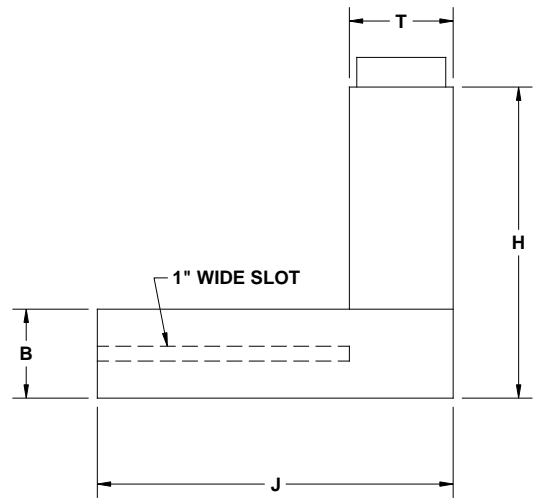

SIDE VIEW

CONSTRUCTION: All welded 18 GA. galvanized steel, 304 or 316 stainless steel with 2B finish or #3 ground and polished and .063 aluminum mill finish. Heavier gauges available: 16, 14, 12 and 10.
DIMENSIONS: As required for job conditions.

Qty.	Material	Gauge	W	H	A	B	ΘW	Nominal D	Actual O.D / I.D.
E	F	G	J	T	Finish	Options	Tag		

To maintain KEES' policy of continuous product development, we reserve the right to change prices, specifications, ratings and dimensions without notice or obligation.

Project		Location	
Engineer		Dwg. No.	SD-SSBH
Architect		Date	06/17
Contractor			



KEES INCORPORATED
 400 S. Industrial Dr.
 Elkhart Lake, WI 53020
 Phone: (920) 876-3391
 Fax: (920) 876-3065
 Website: www.kees.com