

# STAINLESS STEEL CURVED BLADE REGISTERS AND GRILLES

304 (Standard) or 316 (Optional) Stainless - Satin Finish

20 GA. Frame, 24 GA. Blades

Maximum single piece size for curved blade grille is 60" x 48" or 48" x 60".

See reverse side for butting details on multiple piece grilles.

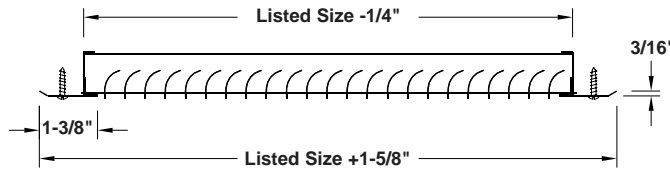
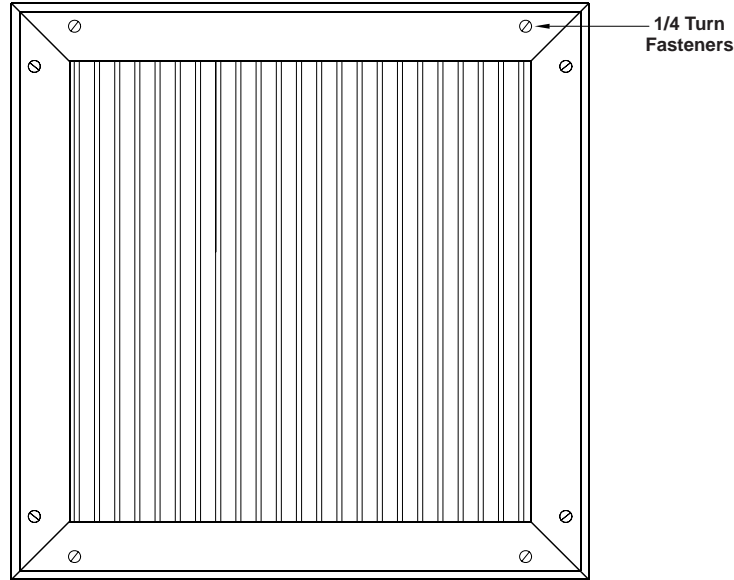

### ACCESSORIES

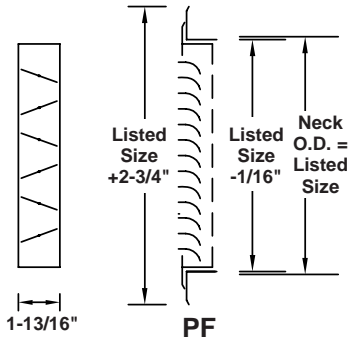

### THROW PATTERNS

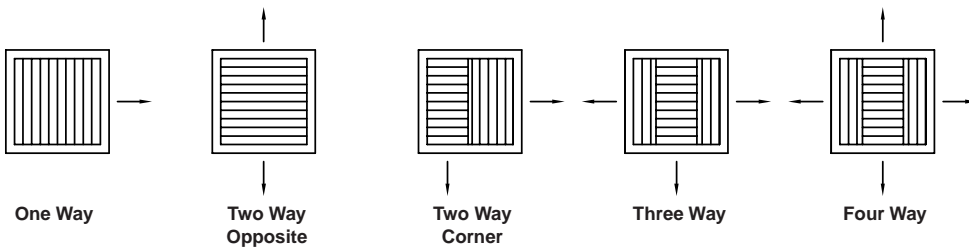

Quantity	W	H	Throw Pattern	Type S.S.		S.S. OBD	Accessories	Tag
				304	316			

To maintain KEES' policy of continuous product improvement, we reserve the right to change prices, specifications, ratings or dimensions without notice or obligation.

<b>Project</b>				<b>Location</b>			
<b>Engineer</b>							
<b>Architect</b>			<b>Dwg. No.</b>	<b>SD-SSCU</b>		<b>KEES INCORPORATED</b> 400 S. Industrial Dr. • P.O. Box L Elkhart Lake, WI 53020 Phone: (920) 876-3391 Fax: (920) 876-3065 Website: www.kees.com	
<b>Contractor</b>			<b>Date</b>	<b>08/09</b>			

# STAINLESS STEEL CURVED BLADE REGISTERS AND GRILLES

**304 (Standard) or 316 (Optional) Stainless - Satin Finish**

20 GA. Frame, 24 GA. Blades

Maximum single piece size for curved blade grille is 60" x 48" or 48" x 60".  
Larger order sizes will be made in multiple individual sections to fit opening size.  
Mullion supports within opening to be provided by others.

## BUTTING DETAIL

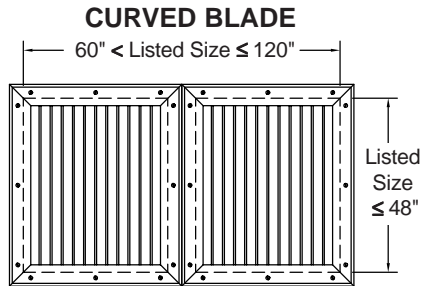
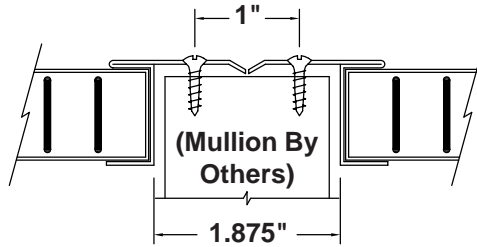

OR

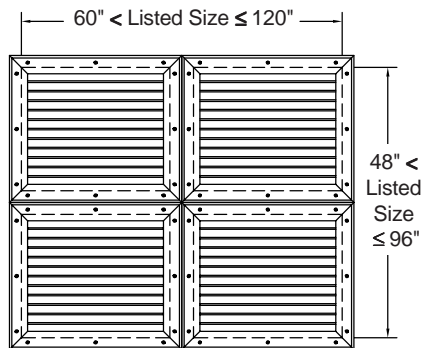
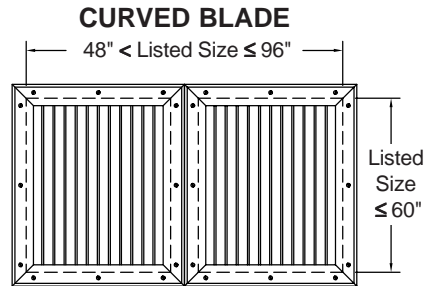

OR

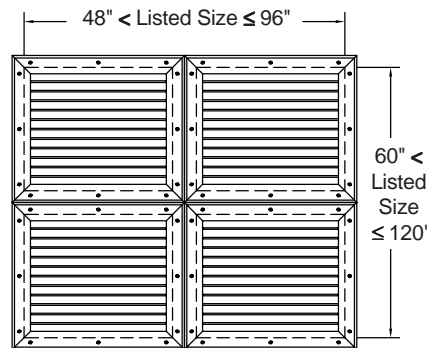

To maintain KEES' policy of continuous product improvement, we reserve the right to change prices, specifications, ratings or dimensions without notice or obligation.

<b>Project</b>		<b>Location</b>	
<b>Engineer</b>			
<b>Architect</b>	<b>Dwg. No.</b>	<b>SD-SSCU</b>	 <b>KEES INCORPORATED</b> 400 S. Industrial Dr. • P.O. Box L Elkhart Lake, WI 53020 Phone: (920) 876-3391 Fax: (920) 876-3065 Website: www.kees.com
<b>Contractor</b>	<b>Date</b>	<b>08/09</b>	