

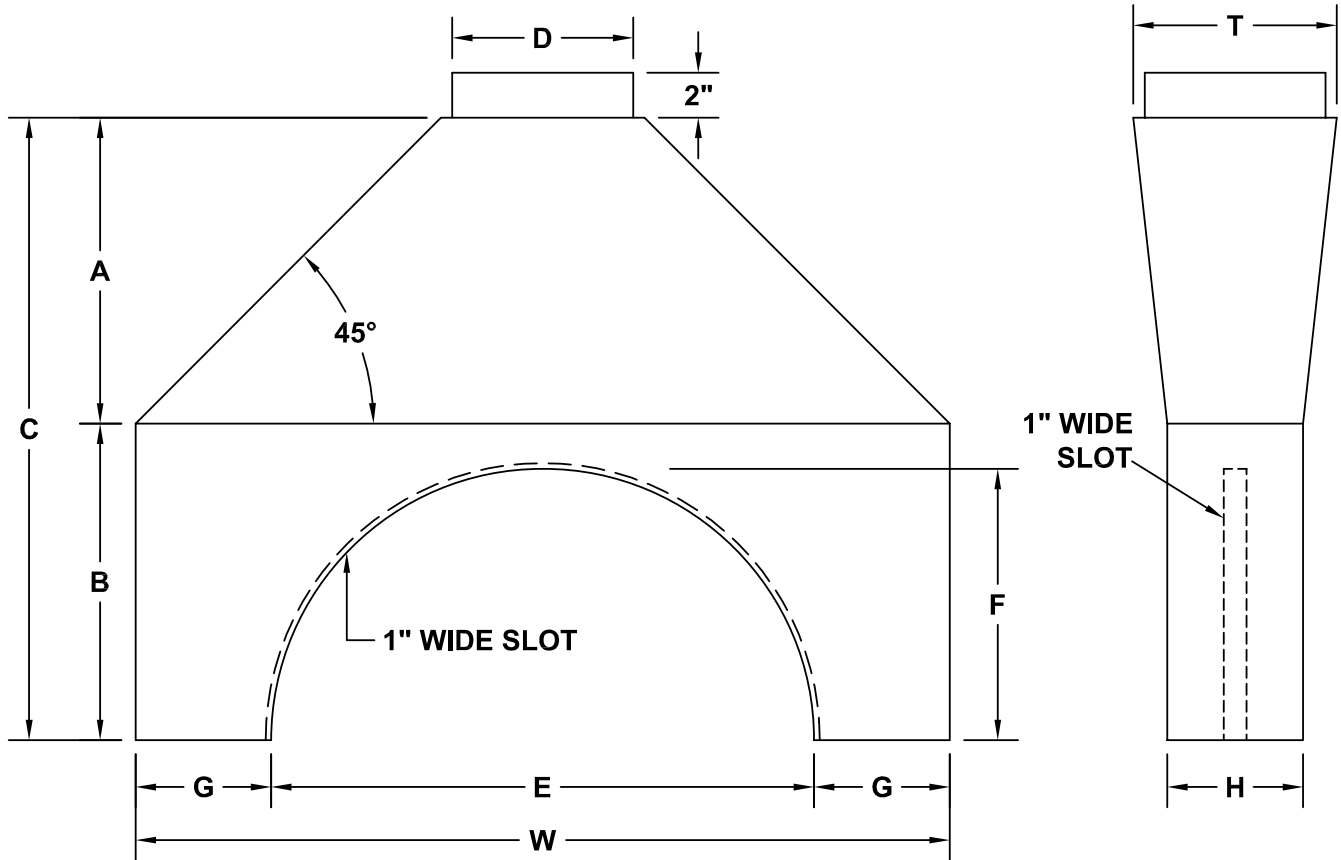

SLOTTED BARREL HOODS



CONSTRUCTION: All welded 18 GA. galvanized steel, 304 or 316 stainless steel with 2B finish or #3 ground and polished and .063 aluminum mill finish. Heavier gauges available: 16, 14, 12 and 10.

DIMENSIONS: As required for job conditions.

Qty.	Material	Gauge	W	H	A	B	C	Nominal D	Actual O.D. / I.D.
E	F	G	T	Finish		Options		Tag	

To maintain KEES' policy of continuous product improvement, we reserve the right to change prices, specifications, ratings or dimensions without notice or obligation.

Project		Location		<p>KEES INCORPORATED 400 S. Industrial Dr. • P.O. Box L Elkhart Lake, WI 53020 Phone: (920) 876-3391 Fax: (920) 876-3065 Website: www.kees.com</p>
Engineer		Dwg. No.	SD-SSBH	
Architect		Date	10/07	
Contractor				



SLOTTED BARREL HOODS

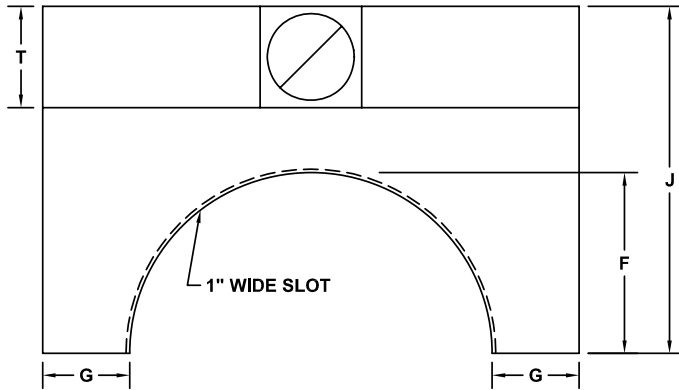

PLAN VIEW

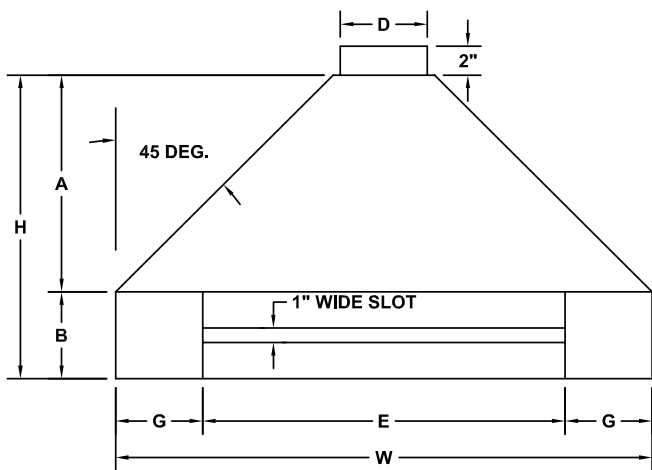

ELEVATION VIEW

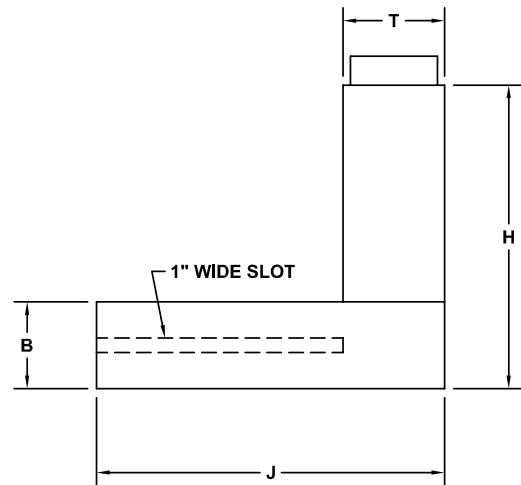

SIDE VIEW

CONSTRUCTION: All welded 18 GA. galvanized steel, 304 or 316 stainless steel with 2B finish or #3 ground and polished and .063 aluminum mill finish. Heavier gauges available: 16, 14, 12 and 10.

DIMENSIONS: As required for job conditions.

Qty.	Material	Gauge	W	H	A	B	Nominal D	Actual O.D./I.D.
E	F	G	J	T	Finish	Options	Tag	

To maintain KEES' policy of continuous product improvement, we reserve the right to change prices, specifications, ratings or dimensions without notice or obligation.

Project		Location	
Engineer			
Architect		Dwg. No.	SD-SSBH
Contractor		Date	10/07

KEES INCORPORATED
 400 S. Industrial Dr. • P.O. Box L
 Elkhart Lake, WI 53020
 Phone: (920) 876-3391
 Fax: (920) 876-3065
 Website: www.kees.com