

SEG-9TG SECURITY TRANSFER GRILLE - REMOVABLE FACE

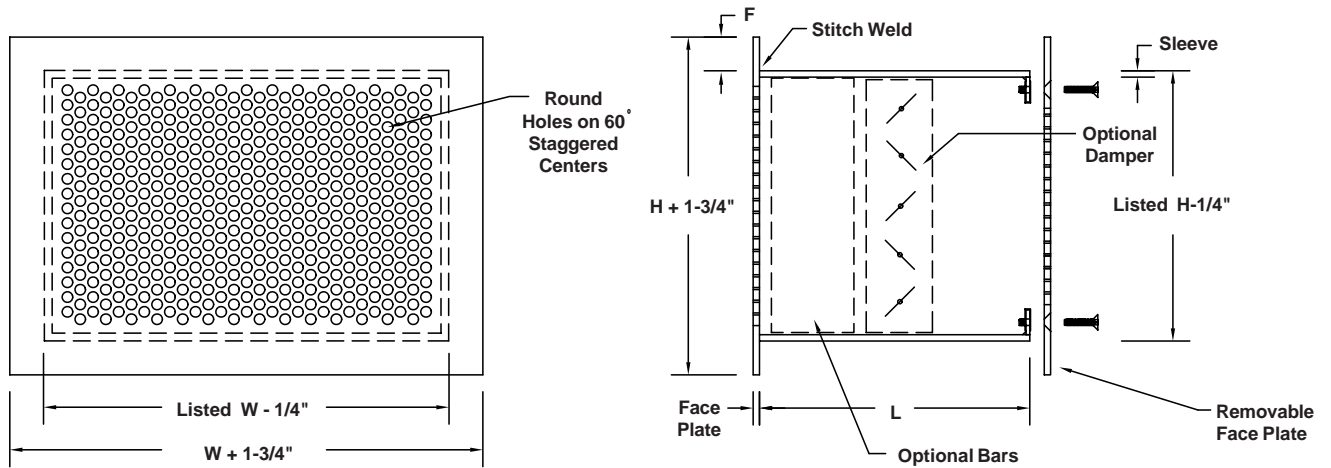

STANDARD CONSTRUCTION

Face: 3/16" thick steel stitch welded to sleeve. 1" face flange.
Hole Pattern: 5/16" diameter holes on 7/16" staggered centers.
Sleeve: 3/16" steel with continuously welded or formed seams.
Finish: Two part polyurethane inside and out. White.

REQUIRED CONSTRUCTION:

- Face Material:** 3/16" steel (Std.)
 10 ga. steel
 12 ga. steel
 Other _____
- Hole Pattern:** 5/16" dia. holes on 7/16" centers (Std.)
 1/4" dia. holes on 3/8" centers
 Other _____
- Flange "F":** 1" (Std.)
 Other _____
- Sleeve Material:** 3/16" steel (Std.)
 10 ga. steel
 12 ga. steel
 14 ga. steel
 Other _____
- Finish:** White (Std.)
 Other _____
- Other Material:** **SEG-9TGA** all aluminum construction
 3/16" or 1/8" thick.
- SEG-9TGSS** all stainless steel construction
 10 ga. type 304.

MOUNTING OPTIONS:

- 26.** Countersunk screw holes in removable face 10" o.c. with #10-24 x 1" long Torx security machine screws. Screws thread into foldover nuts 10 ga. steel internal flange stitch welded to sleeve.

ACCESSORIES:

- 16F.** Opposed blade damper tack welded into sleeve. operable through fixed face..
- 16R.** Opposed blade damper tack welded into sleeve, operable through removable face.
- 21.** 2-1/2" x 3/8" hot rolled steel vertical security bars 4" o.c., welded to sleeve.
- Other:** _____

Qty.	Listed Size		Sleeve O.D.		Masonry Opening		Sleeve Length L	Wall Thickness	Mounting	Accessories	Tag
	W	H	W	H	W	H					

To maintain KEES' policy of continuous product improvement, we reserve the right to change prices, specifications, ratings or dimensions without notice or obligation.

Project			Location		
Architect / Engineer			Contractor		
Representative		Dwg. No.	SEG-9TGw 07/20/04		 KEES INCORPORATED 400 S. Industrial Dr. • P.O. Box L Elkhart Lake, WI 53020 Phone: (920) 876-3391 Fax: (920) 876-3065 Website: www.kees.com
		Date			

SEG-9TGFF SECURITY TRANSFER GRILLE - FIXED FACES

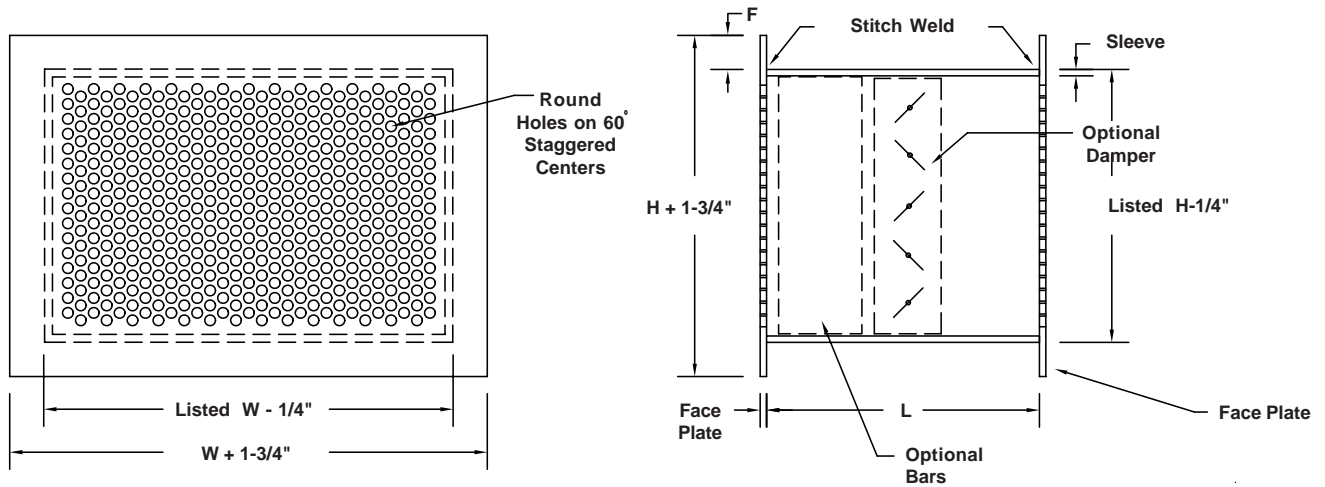

STANDARD CONSTRUCTION

Face: 3/16" thick steel stitch welded to sleeve. 1" face flange.
Hole Pattern: 5/16" diameter holes on 7/16" staggered centers.
Sleeve: 3/16" steel with continuously welded or formed seams.
Finish: Two part polyurethane inside and out. White.

REQUIRED CONSTRUCTION:

- Face Material:** 3/16" steel (Std.)
 10 ga. steel
 12 ga. steel
 Other _____
- Hole Pattern:** 5/16" dia. holes on 7/16" centers (Std.)
 1/4" dia. holes on 3/8" centers
 Other _____
- Flange "F":** 1" (Std.)
 Other _____
- Sleeve Material:** 3/16" steel (Std.)
 10 ga. steel
 12 ga. steel
 14 ga. steel
 Other _____
- Finish:** White (Std.)
 Other _____
- Other Material:** **SEG-9TGFFA** all aluminum construction
 3/16" or 1/8" thick.
- SEG-9TGFFSS** all stainless steel construction
 10 ga. type 304.

MOUNTING OPTIONS:

- 26FF.** Both faces factory welded to sleeve. Grille must be set with block or poured in place.

ACCESSORIES:

- 16F.** Opposed blade damper tack welded into sleeve. operable through face..
- 21.** 2-1/2" x 3/8" hot rolled steel vertical security bars 4" o.c., welded to sleeve.
- Other:** _____

Qty.	Listed Size		Sleeve O.D.		Masonry Opening		Sleeve Length L	Wall Thickness	Mounting	Accessories	Tag
	W	H	W	H	W	H					

To maintain KEES' policy of continuous product improvement, we reserve the right to change prices, specifications, ratings or dimensions without notice or obligation.

Project				Location						
Architect / Engineer				 KEES INCORPORATED 400 S. Industrial Dr. • P.O. Box L Elkhart Lake, WI 53020 Phone: (920) 876-3391 Fax: (920) 876-3065 Website: www.kees.com						
Contractor			Dwg. No.					SEG-9TGRFFw 01/20/05		
Representative			Date							