

SEG-6 SECURITY GRILLE — SUPPLY OR RETURN

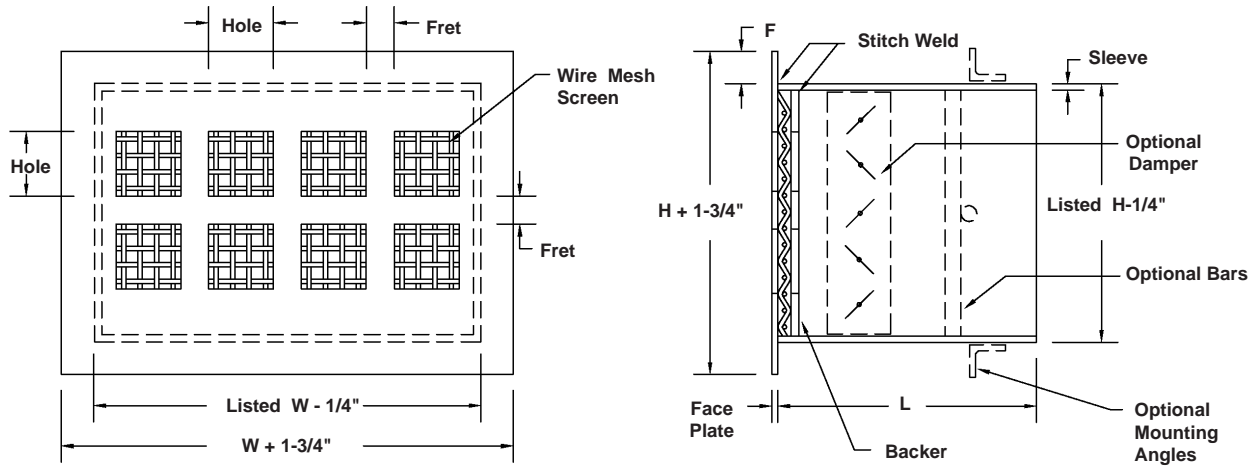

STANDARD CONSTRUCTION

Face: 3/16" thick steel stitch welded to sleeve. 1" face flange.
Hole Pattern: 2" x 2" holes with 1" frets *.
Backer: 3/16" thick steel stitch welded inside sleeve.
Screen: 10 ga. (.135" dia. wire) x #2 mesh (1/2" centers).
Sleeve: 3/16" steel with continuously welded or formed seams.
Finish: Two part polyurethane inside and out. White.

REQUIRED CONSTRUCTION:

- Face Material:**
 - 3/16" steel (Std.)
 - 1/4" thick steel
 - Other _____
- Backer Material:**
 - 3/16" thick steel (Std.)
 - 1/4" thick steel
 - Other _____
- Hole Pattern:**
 - 2" x 2" holes with 1" frets* (Std.)
 - Other _____
- Flange "F":**
 - 1" (Std.)
 - Other _____
- Sleeve Material:**
 - 3/16" steel (Std.)
 - 10 ga. steel
 - Other _____
- Finish:**
 - White (Std.)
 - Other _____
- Other Material:**
 - SEG-6A** all aluminum construction 3/16" or 1/8" thick.
 - SEG-6SS** all stainless steel construction 10 ga. type 304.

MOUNTING OPTIONS:

- 11A.** Two loose pieces of 1" x 1" x 3/16" mill finish steel angle loose for field welding. Length equal to longest side of grille. Other angle size _____
- 11B.** Rear angle frame of 1" x 1" x 3/16" mill finish steel completely assembled for field welding. Other angle size _____
- 12A.** Rear angle frame for bolting to sleeve. 1" x 1" x 3/16" steel with bolt holes 8" o.c. for 1/4" dia. bolts. No holes in sleeve. No bolts, nuts or washers. Other angle size _____
- 12B.** Same as 12A with the addition of bolt holes in sleeve. (Advise wall or ceiling thickness). Other angle size _____
- 23.** Masonry anchors: 1/2" x 3" anchors 16" o.c., one per side minimum, welded to sleeve exterior. Other size or spacing _____
- 24.** Countersunk screw holes in face 10" o.c. with #10-24 x 2" long Torx security machine screws for 1-1/2" maximum ceiling thickness. 1" x 1" x 1/8" steel angle frame with matching holes and foldover nuts. Requires 1-1/2" flange.
- 25.** Countersunk screw holes in face 10" o.c. with #10 x 1-1/2" long Torx security screws. Other screw length _____

ACCESSORIES:

- 16F.** Face operated opposed blade damper tack welded into sleeve. Dampers are adjustable using flat bladed screwdriver.
- 16R.** Rear operated opposed blade damper tack welded into sleeve.
- 19.** 1/2" dia. A-36 mild steel security bars 6" o.c. both ways, welded to sleeve and at intersections. Other bars size/spacing _____
- Other:** _____

* Frets may be reduced to 7/8" to allow additional holes.

Qty.	Listed Size		Sleeve O.D.		Masonry Opening		Sleeve Length L	Wall / Ceiling Thickness	Accessories	Mounting Option	Tag
	W	H	W	H	W	H					

To maintain KEES' policy of continuous product improvement, we reserve the right to change prices, specifications, ratings or dimensions without notice or obligation.

Project				Location			
Architect / Engineer				<div style="display: flex; align-items: center;"> <div> <p>KEES INCORPORATED Elkhart Lake, WI 53020 Phone: (920) 876-3391 Fax: (920) 876-3065 Website: www.kees.com</p> </div> </div>			
Contractor			Dwg. No.	SEG-6w 05/21/08			
Representative			Date				