

# SEG-5 SECURITY GRILLE – SUPPLY OR RETURN

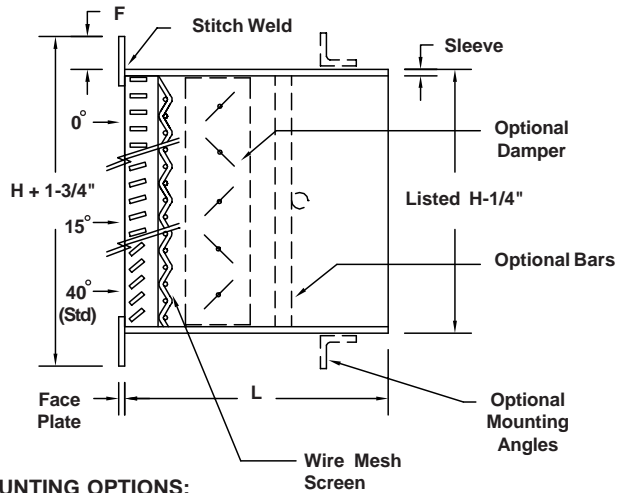
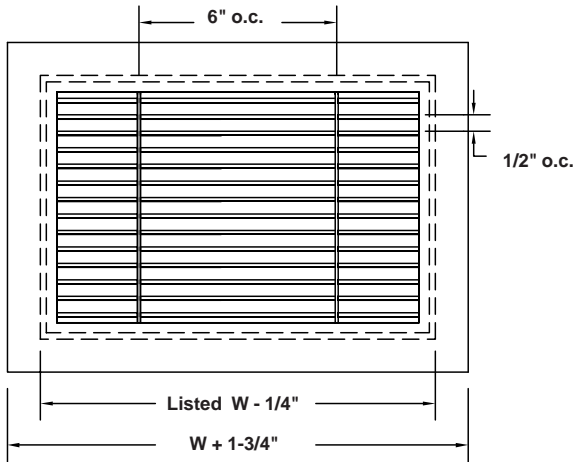

**STANDARD CONSTRUCTION**

**Face:** 14 ga. steel stitch welded to sleeve. 1" face flange.  
**Blades:** 1/2" x 1/8" steel bars on 1/2" centers. Available on 40 degree (Std.) deflection, 0 or 15 degree. Blades penetrate supports and are welded to sleeve.  
**Supports:** 14 ga. steel 6" o.c., stitch welded inside sleeve.  
**Screen:** 10 ga. (.135" dia. wire) x #2 mesh (1/2" centers).  
**Sleeve:** 14 ga. steel with continuously welded or formed seams.  
**Finish:** Two part polyurethane inside and out. White.

**REQUIRED CONSTRUCTION:**

- Face Material:**  14 ga. steel (Std.)  
 Other \_\_\_\_\_
- Deflection:**  40 degree (Std.)  
 15 degree  
 0 degree
- Flange "F":**  1" (Std.)  
 Other \_\_\_\_\_
- Screen:**  10 ga. (.135" dia. wire) x #2 mesh (Std.)  
 No screen.  
 Other \_\_\_\_\_
- Sleeve Material:**  14 ga. steel (Std.)  
 Other \_\_\_\_\_
- Finish:**  White (Std.)  
 Other \_\_\_\_\_
- Other Material:**  **SEG-5A** all aluminum construction. 1/8" thick.  
 **SEG-5SS** all stainless steel construction. 14 ga. type 304.

**MOUNTING OPTIONS:**

- 11A.** Two loose pieces of 1" x 1" x 1/8" mill finish steel angle loose for field welding. Length equal to longest side of grille. Other angle size \_\_\_\_\_
  - 11B.** Rear angle frame of 1" x 1" x 1/8" mill finish steel completely assembled for field welding. Other angle size \_\_\_\_\_
  - 12A.** Rear angle frame for bolting to sleeve. 1" x 1" x 1/8" steel with bolt holes 8" o.c. for 1/4" dia. bolts. No holes in sleeve. No bolts, nuts or washers. Other angle size \_\_\_\_\_
  - 12B.** Rear angle frame for bolting to sleeve. 1" x 1" x 1/8" steel with bolt holes in sleeve and frame 8" o.c. for 1/4" dia. bolts. No bolts, nuts or washers. (Advise wall or ceiling thickness). Other angle size \_\_\_\_\_
  - 23.** Masonry anchors: 1/2" x 3" anchors 16" o.c., one per side minimum, welded to sleeve exterior. Other size or spacing \_\_\_\_\_
  - 24.** Countersunk screw holes in face 10" o.c. with #10-24 x 2" long Torx security machine screws for maximum 1-1/2" ceiling thickness. 1" x 1" x 1/8" steel angle frame with matching holes and foldover nuts. Requires 1-1/2" flange.
  - 25.** Countersunk screw holes in face 10" o.c. with #10 x 1-1/2" long Torx security sheet metal screws. Other screw length \_\_\_\_\_
- ACCESSORIES:**
- 16F.** Face operated opposed blade damper tack welded into sleeve.
  - 16R.** Rear operated opposed blade damper tack welded into sleeve.
  - 19.** 1/2" dia. A-36 mild steel bars 6" o.c. both ways, welded to sleeve and at intersections.
  - Other:** \_\_\_\_\_

Qty.	Listed Size		Sleeve O.D.		Masonry Opening		Sleeve Length L	Wall Thickness	Accessories	Mounting Option	Tag
	W	H	W	H	W	H					

To maintain KEES' policy of continuous product improvement, we reserve the right to change prices, specifications, ratings or dimensions without notice or obligation.

<b>Project</b>		<b>Location</b>	
<b>Architect / Engineer</b>			
<b>Contractor</b>		<b>Dwg. No.</b>	SEG-5W 03/29/06
<b>Representative</b>		<b>Date</b>	

**KEES INCORPORATED**  
 400 S. Industrial Dr. • P.O. Box L  
 Elkhart Lake, WI 53020  
 Phone: (920) 876-3391  
 Fax: (920) 876-3065  
 Website: www.kees.com