

# SEG-13R RISK RESISTANT SECURITY GRILLE

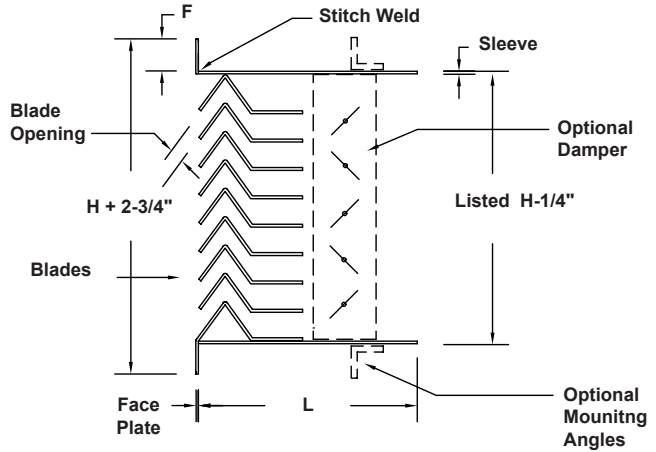
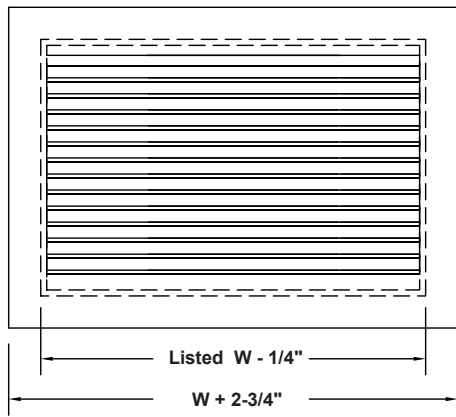

### STANDARD CONSTRUCTION

**Face:** 12 ga. steel stitch welded to sleeve. 1-1/2" face flange.  
**Blades:** 12 ga. steel blades with 1/2" opening welded to sleeve.  
**Sleeve:** 12 ga. steel with continuously welded or formed seams.  
**Finish:** Two part polyurethane inside and out. White.

### REQUIRED CONSTRUCTION:

- Face Material:**  12 ga. steel (Std.)  
 Other \_\_\_\_\_
- Blade Opening:**  1/2" (Std.)  
 3/8"  
 1/4"  
 3/16"  
 Other \_\_\_\_\_
- Flange "F":**  1-1/2" (Std.)  
 Other \_\_\_\_\_
- Sleeve Material:**  12 ga. steel (Std.)  
 Other \_\_\_\_\_
- Finish:**  White (Std.)  
 Other \_\_\_\_\_
- Other Material:**  SEG-13R-A 10 ga. (.100") aluminum.  
 SEG-13R-SS 14 ga. 304 stainless steel

### MOUNTING OPTIONS:

- 11A.** Two loose pieces of 1" x 1" x 3/16" mill finish steel angle loose for field welding to sleeve. Length equal to longest side of grille. Other angle size \_\_\_\_\_
- 11B.** Rear angle frame of 1" x 1" x 3/16" mill finish steel completely assembled for field welding to sleeve. Other angle size \_\_\_\_\_
- 12A.** Rear angle frame for bolting to sleeve. 1" x 1" x 3/16" steel with bolt holes 8" o.c. for 1/4" dia. bolts. No holes in sleeve. No bolts, nuts or washers. Other angle size \_\_\_\_\_
- 12B.** Same as **12A** with the addition of bolt holes in sleeve. (Advise wall or ceiling thickness). Other angle size \_\_\_\_\_
- 23.** Masonry anchors: 1/2" x 3" Anchors 16" o.c., one per side minimum, welded to sleeve exterior. Other size or spacing \_\_\_\_\_
- 24.** Countersunk screw holes in face 10" o.c. with #10-24 x 2" long Torx security machine screws for 1-1/2" maximum ceiling thickness. 1" x 1" x 1/8" steel angle frame with matching holes and foldover nuts. Requires 1-1/2" flange.
- 25.** Countersunk screw holes in face 10" o.c. with #10 x 1-1/2" long Torx security sheet metal screws. Other screw length \_\_\_\_\_
- ACCESSORIES:**
- 16R.** Rear operated opposed blade damper tack welded into sleeve. Dampers are adjustable using flat bladed screwdriver.
- 19.** 1/2" dia. A-36 mild steel security bars 6" o.c. both ways, welded to sleeve and at intersections.
- Other:** \_\_\_\_\_

Qty.	Listed Size		Sleeve O.D.		Masonry Opening		Sleeve Length L	Wall / Ceiling Thickness	Accessories	Mounting Option	Tag
	W	H	W	H	W	H					

To maintain KEES' policy of continuous product improvement, we reserve the right to change prices, specifications, ratings or dimensions without notice or obligation.

<b>Project</b>				<b>Location</b>						
<b>Architect / Engineer</b>				<b>KEES INCORPORATED</b> Elkhart Lake, WI 53020 Phone: (920) 876-3391 Fax: (920) 876-3065 Website: www.kees.com						
<b>Contractor</b>			<b>Dwg. No.</b>					SEG-13Rw 05/21/08		
<b>Representative</b>			<b>Date</b>							