

SEG-13DG SECURITY DOOR GRILLE

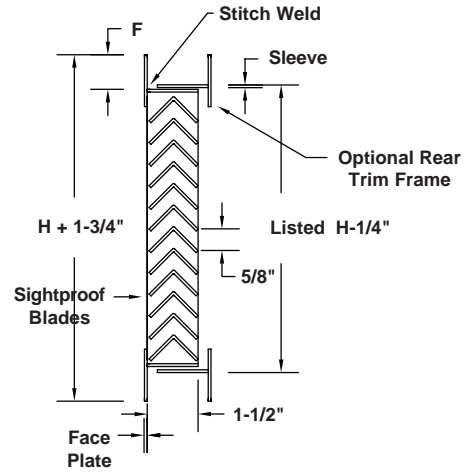
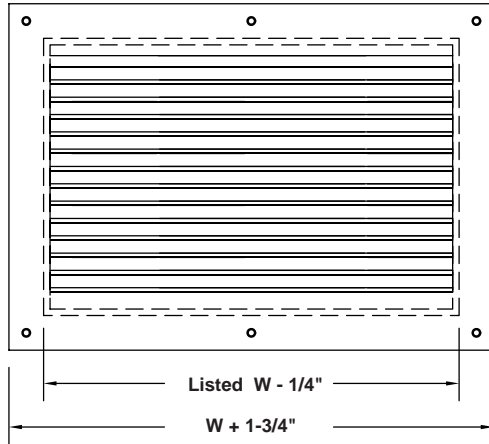

STANDARD CONSTRUCTION

Face: 14 ga. steel stitch welded to sleeve. 1" face flange.
Blades: 1" x 1" x 14 ga. steel angles on 5/8" centers. Blades penetrate and are welded to sleeve.
Sleeve: 14 ga. steel with continuously welded or formed seams.
Finish: Two part polyurethane inside and out. White.

MOUNTING OPTIONS:

- Rear Trim Frame:** Same material and thickness as face and sleeve.
- 25.** Countersunk screw holes in face 10" o.c. with #10 x 1/2" long Torx security sheet metal screws. Other screw length _____

REQUIRED CONSTRUCTION:

Face Material: 14 ga. steel (Std.)
 10 ga. steel
 Other _____

Blade Material: 14 ga. steel (Std.)
 10 ga. steel

Blade Centers: 5/8" (Std.)
 Other _____

Flange "F": 1" (Std.)
 Other _____

Sleeve Material: 14 ga. steel (Std.)
 10 ga. steel
 Other _____

Finish: White (Std.)
 Other _____

Other Material: SEG-13DGA all aluminum construction.

SEG-13DGSS all stainless steel construction

Other: _____

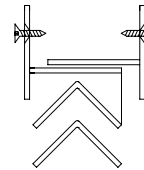

- 35.** Straight screw holes in face 10" o.c. with #10-24 x 2" long carriage bolts and Nylock nuts.

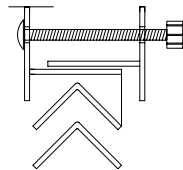

Qty.	Listed Size		Sleeve O.D.		Door Opening		Sleeve Length L	Door Thickness	Trim Frame	Mounting Option	Tag
	W	H	W	H	W	H					

To maintain KEES' policy of continuous product improvement, we reserve the right to change prices, specifications, ratings or dimensions without notice or obligation.

Project			Location				
Architect / Engineer			<p>KEES INCORPORATED 400 S. Industrial Dr. • P.O. Box L Elkhart Lake, WI 53020 Phone: (920) 876-3391 Fax: (920) 876-3065 Website: www.kees.com</p>				
Contractor		Dwg. No.				SEG-13DGw 03/30/06	
Representative		Date					