

SEG-11 SECURITY GRILLE – SUPPLY OR RETURN

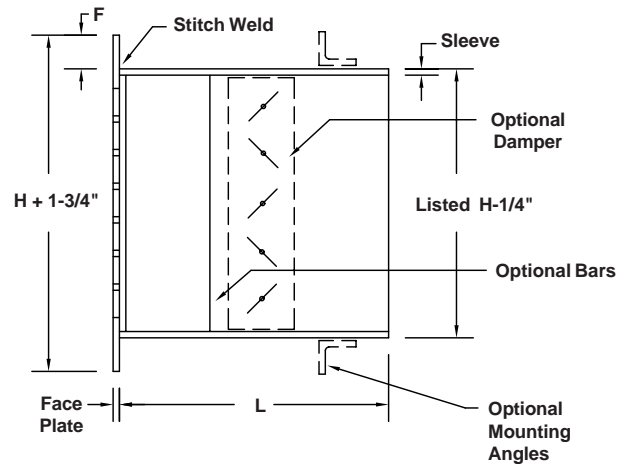
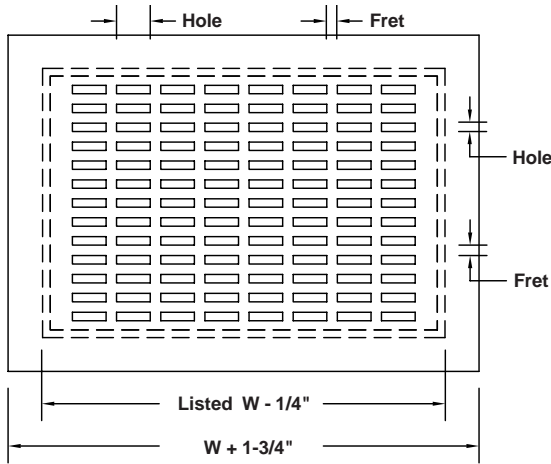

STANDARD CONSTRUCTION

Face: 10 ga. steel stitch welded to sleeve. 1" face flange.
Hole Pattern: 1" x 1/4" holes with 5/16" frets.
Sleeve: 10 ga. steel with continuously welded or formed seams.
Finish: Two part polyurethane inside and out. White.

REQUIRED CONSTRUCTION:

- Face Material:** 10 ga. steel (Std.)
 12 ga. steel
 14 ga. steel
 Other _____
- Hole Pattern:** 1" x 1/4" holes with 5/16" frets (Std.)
 Other _____
- Flange "F":** 1" (Std.)
 Other _____
- Sleeve Material:** 10 ga. steel (Std.)
 12 ga. steel
 14 ga. steel
 Other _____
- Finish:** White (Std.)
 Other _____
- Other Material:** **SEG-11A** all aluminum construction 1/8" thick.
 SEG-11SS all stainless steel construction 12 ga. type 304.

MOUNTING OPTIONS:

- 11A.** Two loose pieces of 1" x 1" x 1/8" mill finish steel angle loose for field welding. Length equal to longest side of grille. Other angle size _____
- 11B.** Rear angle frame of 1" x 1" x 1/8" mill finish steel completely assembled for field welding. Other angle size _____
- 12A.** Rear angle frame for bolting to sleeve. 1" x 1" x 1/8" steel with bolt holes 8" o.c. for 1/4" dia. bolts. No holes in sleeve. No bolts, nuts or washers. Other angle size _____
- 12B.** Rear angle frame for bolting to sleeve. 1" x 1" x 1/8" steel with bolt holes in sleeve and frame 8" o.c. for 1/4" dia. bolts. No bolts, nuts or washers. (Advise wall or ceiling thickness). Other angle size _____
- 23.** Masonry anchors: 1/2" x 3" Anchors 16" o.c., one per side minimum, welded to sleeve exterior. Other size or spacing _____
- 24.** Countersunk screw holes in face 10" o.c. with #10-24 x 2" long Torx security machine screws for 1-1/2" maximum ceiling thickness. 1" x 1" x 1/8" steel angle frame with matching holes and foldover nuts. Requires 1-1/2" flange.
- 25.** Countersunk screw holes in face 10" o.c. with #10 x 1-1/2" long Torx security sheet metal screws. Other screw length _____
- ACCESSORIES:**
- 16F.** Face operated opposed blade damper tack welded into sleeve.
- 16R.** Rear operated opposed blade damper tack welded into sleeve.
- 21.** 2-1/2" x 3/8" A-36 mild steel vertical bars 4" o.c., welded to sleeve.
- Other:** _____

Qty.	Listed Size		Sleeve O.D.		Masonry Opening		Sleeve Length L	Wall Thickness	Accessories	Mounting Option	Tag
	W	H	W	H	W	H					

To maintain KEES' policy of continuous product improvement, we reserve the right to change prices, specifications, ratings or dimensions without notice or obligation.

Project		Location		
Architect / Engineer			<p>KEES INCORPORATED 400 S. Industrial Dr. • P.O. Box L Elkhart Lake, WI 53020 Phone: (920) 876-3391 Fax: (920) 876-3065 Website: www.kees.com</p>	
Contractor		Dwg. No.		SEG-11W 03/29/06
Representative		Date		