

MODEL NTS ROOF CURBS

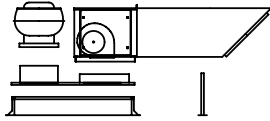

Modular Roof Curb and Support Legs Arrangement A1

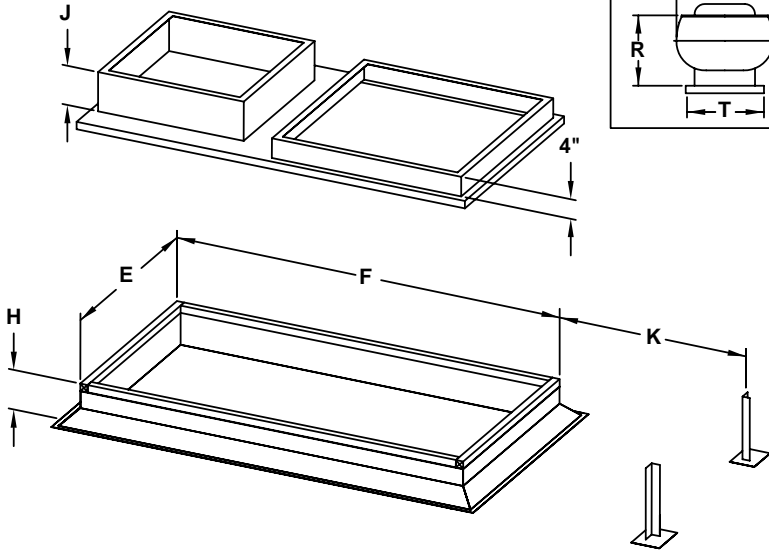
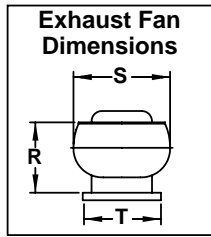

Plan View of Curb Cap

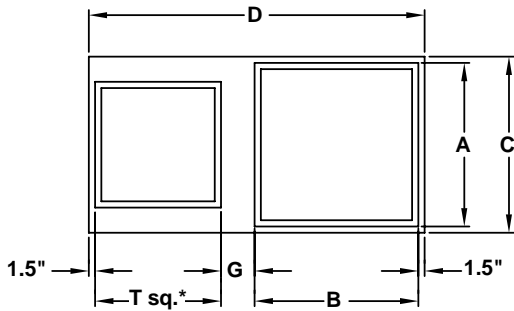

* See Note 4

$C = A+3"$ or $T+3"$ (largest)
 $D = B+G+T+3"$
 $E = C-1"$
 $F = D-1"$
 $G = \left(\frac{S-T}{2}\right)+3"$
 $J = 40"-H-R$ (4" min.)

Select One Roof Curb Model

Model #1

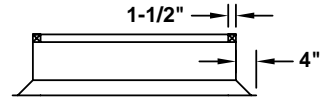

Model #3

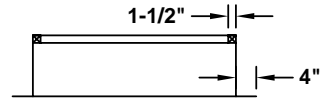

Select One Housing Arrangement

Blower + Filter + Intake

H1

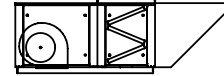

Blower + Intake with Filters

H2

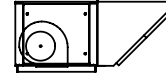

Blower + Extended Intake

H4

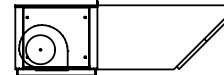

Pitch - (1 or 2-way)

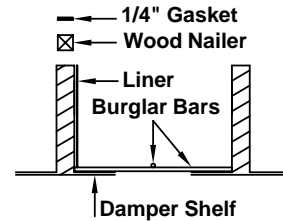
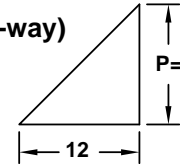

OPTIONS:

- | | |
|---------------------------|-------------------|
| -07 Wood Nailer - Treated | -16 One Way Pitch |
| -10 Aluminum Construction | -17 Two Way Pitch |
| -11 1/4" Neoprene Gasket | -18 Burglar Bars |
| -12 Inner Liner | -19 Damper Shelf |

NOTES:

- Standard construction - 18 gauge galvanized with fiberglass insulation.
- See reverse side for Curb Arrangements A2, A3 & A4.
- Support legs are not required with Housing Arrangement H2.
- Dimension T is the actual exhaust fan curb cap I.D.. KEES will undersize by 1/2".
- To meet NFPA 96 requirements the SF intake and EF discharge must have a 10 foot separation (i.e. supply fan overall length plus dimension G ≥ 120').

Qty.	Fan Size (NTS)	A	B	C	D	E	F	G	H	J	K	Exhaust Fan Make & Model or R, S and T	Options	Tag
	-109/110	31.50	31.50								48.00			
	-112/115	39.50	39.50								48.00			
	-118/120	51.00	55.75								48.00			
	-218/220	99.50	55.75								48.00			

To maintain KEES' policy of continuous product improvement, we reserve the right to change prices, specifications, ratings or dimensions without notice or obligation.

Project		Location		
Engineer		 KEES INCORPORATED 400 S. Industrial Dr. • P.O. Box L Elkhart Lake, WI 53020 Phone: (920) 876-3391 Fax: (920) 876-3065 Website: www.kees.com		
Architect	Dwg. No.			SD-NTS-CURB
Contractor	Date			06/03

MODEL NTS ROOF CURBS

Roof Curb and Support Legs Arrangement A2

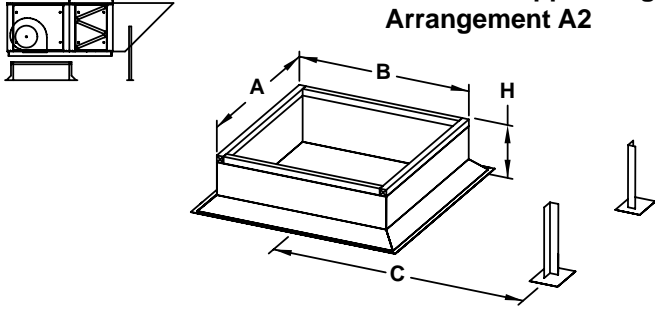

Select One Roof Curb Model

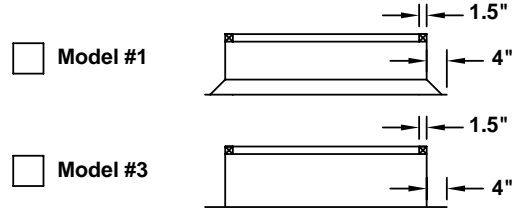

Select One Housing Arrangement

Blower + Filter + Intake

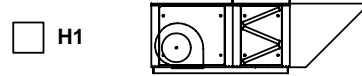

Blower + Intake with Filters



Blower + Extended Intake

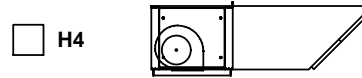

Support Rails Arrangement A3

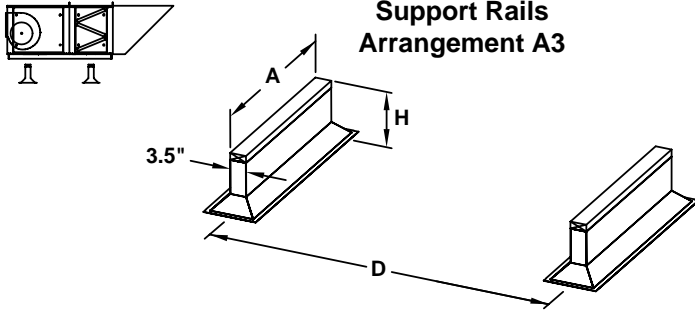

Full Perimeter Roof Curb Arrangement A4

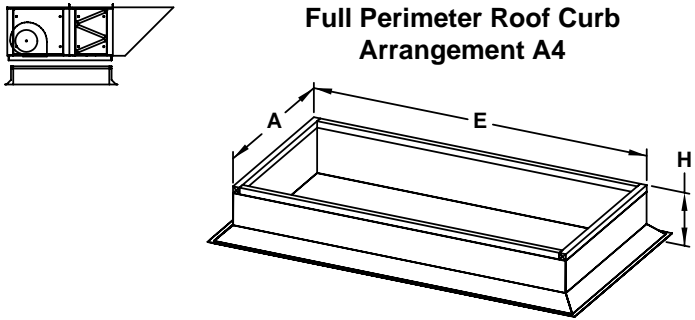

Pitch - (1 or 2-way)

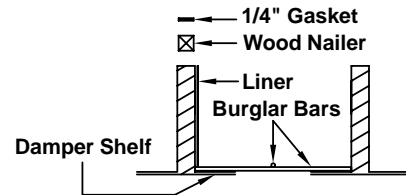
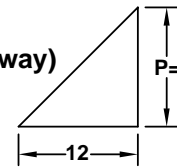

OPTIONS:

- 07 Wood Nailer - Treated
- 10 Aluminum Construction
- 11 1/4" Neoprene Gasket
- 12 Inner Liner
- 16 One Way Pitch
- 17 Two Way Pitch
- 18 Burglar Bars
- 19 Damper Shelf

NOTES:

1. Standard construction - 18 gauge galvanized with fiberglass insulation.
2. See reverse side for Curb Arrangement A1.
3. Curb Arrangement A2 - support legs not required with Housing Arrangement H2.
4. Curb Arrangement A3 and A4 - only available with Housing Arrangement H1.

Qty.	Fan Size (NTS)	Housing	Curb Arrangement A2				Curb Arrangement A3			Curb Arrangement A4			Options	Tag
			A	B	C	H	A	D	H	A	E	H		
	-109/110	#1	31.00	31.00	63.50		31.00	36.00		31.00	59.00			
	-112/115	#2	39.00	39.00	68.50		39.00	42.00		39.00	67.75			
	-118/120	#3	50.50	55.25	76.00		50.50	52.00		50.50	83.50			
	-218/220	#4	99.00	55.25	76.00		99.00	52.00		99.00	83.50			

To maintain KEES' policy of continuous product improvement, we reserve the right to change prices, specifications, ratings or dimensions without notice or obligation.

Project				Location				
Engineer								
Architect				Dwg. No.	SD-NTS-CURB			
Contractor				Date	06/03			



KEES INCORPORATED
 400 S. Industrial Dr. • P.O. Box L
 Elkhart Lake, WI 53020
 Phone: (920) 876-3391
 Fax: (920) 876-3065
 Website: www.kees.com