

# MODEL MUA / DFG ROOF CURBS

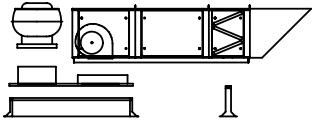

**Modular Roof Curb and Support Rail Arrangement A1**

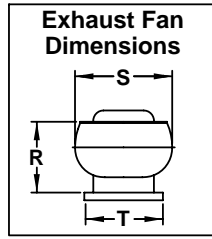

**Exhaust Fan Dimensions**

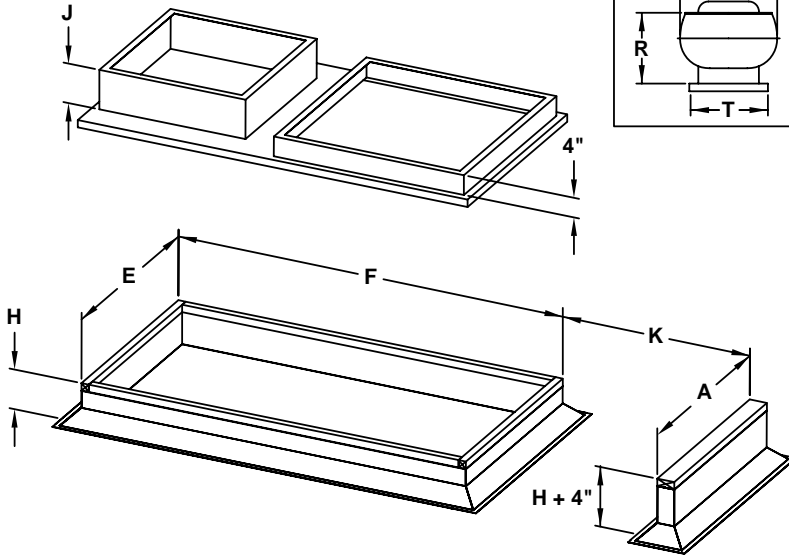

**Plan View of Curb Cap**

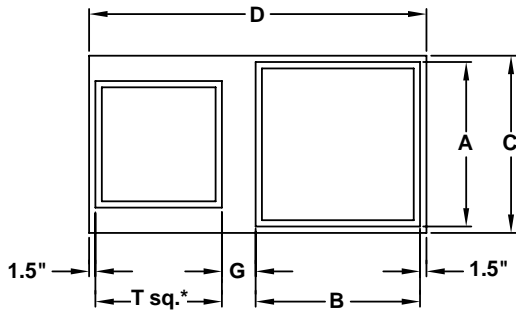

\* See Note 4

$C = A+3"$  or  $T+3"$  (largest)  
 $D = B+G+T+3"$   
 $E = C-1"$   
 $F = D-1"$   
 $G = \left(\frac{S-T}{2}\right)+3"$   
 $J = 40"-H-R$  (4" min.)

**Select One Roof Curb Model**

Model #1

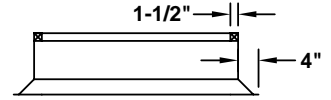

Model #3

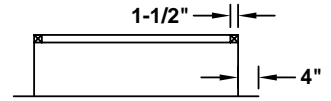

**Select One Housing Arrangement**

H1

**Blower + Heater + Filter + Intake**

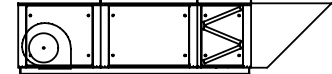

K = 60"

H2

**Blower + Heater + Intake with Filters**

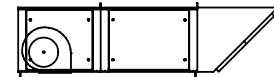

K = 43"

**Pitch - (1 or 2-way)**

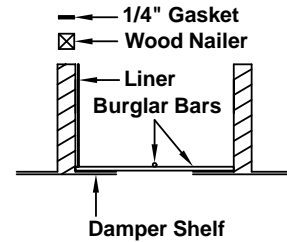
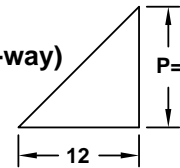

**OPTIONS:**

- 07 Wood Nailer - Treated
- 10 Aluminum Construction
- 11 1/4" Neoprene Gasket
- 12 Inner Liner
- 16 One Way Pitch
- 17 Two Way Pitch
- 18 Burglar Bars
- 19 Damper Shelf

**NOTES:**

1. Standard construction - 18 gauge galvanized with fiberglass insulation.
2. See reverse side for Curb Arrangements A2, A3 & A4.
3. Dimension K is determined by selecting a housing arrangement.
4. Dimension T is the actual exhaust fan curb cap I.D.. KEES will undersize by 1/2".

Qty.	Fan Size (MUA / DFG)	A	B	C	D	E	F	G	H	J	K	Exhaust Fan Make & Model or R, S and T	Options	Tag
	-109/110	31.50	31.50											
	-112/115	39.50	39.50											
	-118/120	51.00	55.75											
	-218/220	99.50	55.75											

To maintain KEES' policy of continuous product improvement, we reserve the right to change prices, specifications, ratings or dimensions without notice or obligation.

<b>Project</b>				<b>Location</b>			
<b>Engineer</b>							
<b>Architect</b>			<b>Dwg. No.</b>	<b>SD-MUA-CURB</b>			
<b>Contractor</b>			<b>Date</b>	<b>06/03</b>			



**KEES INCORPORATED**  
 400 S. Industrial Dr. • P.O. Box L  
 Elkhart Lake, WI 53020  
 Phone: (920) 876-3391  
 Fax: (920) 876-3065  
 Website: www.kees.com

# MODEL MUA / DFG ROOF CURBS

Roof Curb and Support Rail Arrangement A2

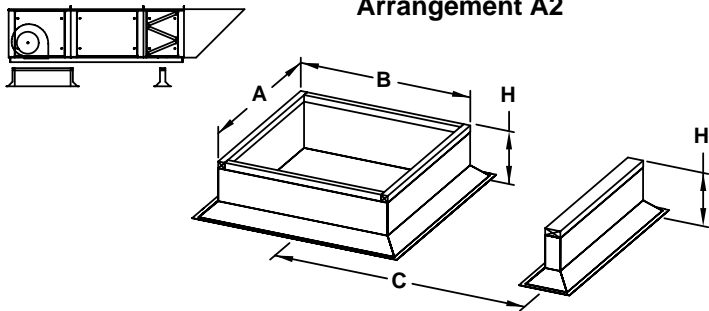

Support Rails Arrangement A3

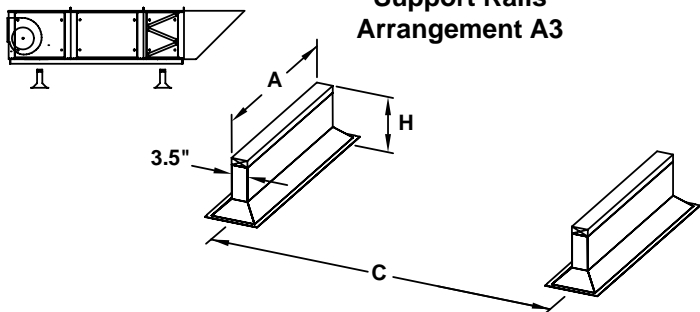

Full Perimeter Roof Curb Arrangement A4

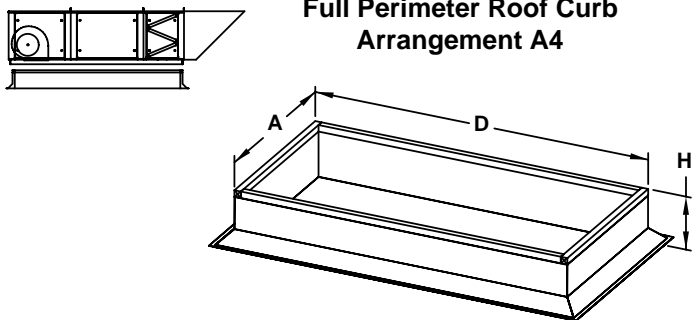

Select One Roof Curb Model

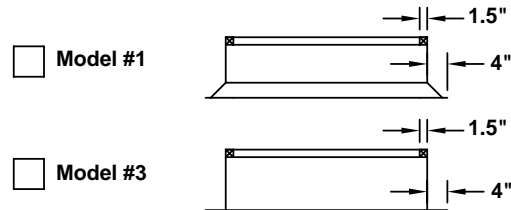

Select One Housing Arrangement

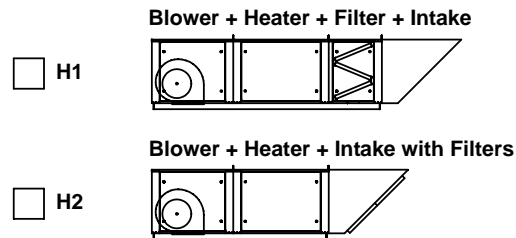

	Housing #1		Housing #2		Housing #3,#4	
	C	D	C	D	C	D
H1	78.50	107.00	83.00	115.75	90.75	131.50
H2	61.50	79.00	65.50	87.00	73.75	103.25

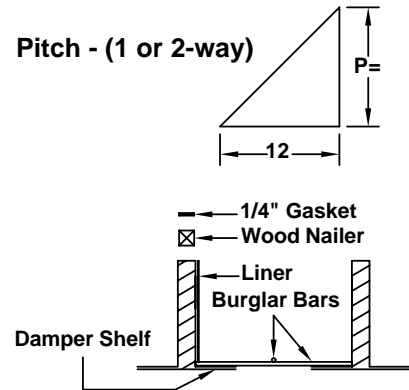

**OPTIONS:**

- 07 Wood Nailer - Treated
- 10 Aluminum Construction
- 11 1/4" Neoprene Gasket
- 12 Inner Liner
- 16 One Way Pitch
- 17 Two Way Pitch
- 18 Burglar Bars
- 19 Damper Shelf

**NOTES:**

1. Standard construction - 18 gauge galvanized with fiberglass insulation.
2. See reverse side for Curb Arrangement A1.
3. Use above table to select dimension C or D as needed.
4. Dimension C is measured from the centerlines of the curb and rail.

Qty.	Fan Size (MUA / DFG)	Housing	Curb Arrangement A2				Curb Arrangement A3			Curb Arrangement A4			Options	Tag
			A	B	C	H	A	C	H	A	D	H		
	-109/110	#1	31.00	31.00			31.00			31.00				
	-112/115	#2	39.00	39.00			39.00			39.00				
	-118/120	#3	50.50	55.25			50.50			50.50				
	-218/220	#4	99.00	55.25			99.00			99.00				

To maintain KEES' policy of continuous product improvement, we reserve the right to change prices, specifications, ratings or dimensions without notice or obligation.

<b>Project</b>		<b>Location</b>	
<b>Engineer</b>		<b>Dwg. No.</b>	
<b>Architect</b>		<b>SD-MUA-CURB</b>	
<b>Contractor</b>		<b>Date</b>	
		<b>06/03</b>	

**KEES INCORPORATED**  
 400 S. Industrial Dr. • P.O. Box L  
 Elkhart Lake, WI 53020  
 Phone: (920) 876-3391  
 Fax: (920) 876-3065  
 Website: www.kees.com