

MODEL KS - Roof Supply Unit Filtered

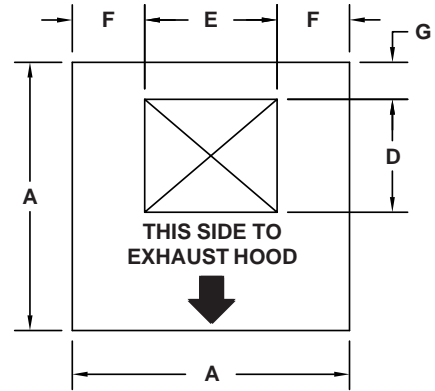
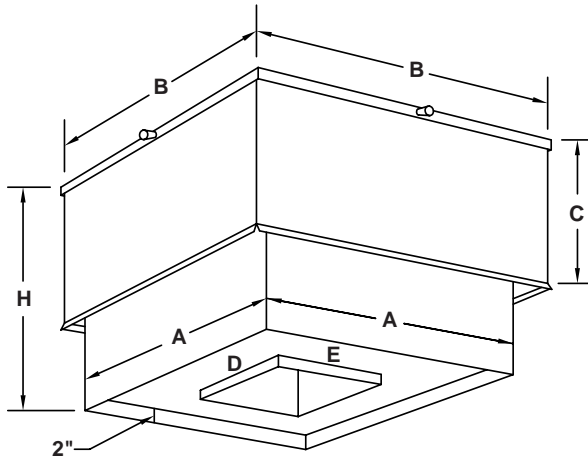

Model Number	Unit Dimensions (Inches)								Filters Quantity And Size	Roof Curb O.D.	Wheels		Outlet Area	Wgt.
	A	B	C	D	E	F	G	H			Dia.	Width		
KS-10	26	36	16	11.5	13	6.5	5	28.5	4- 16 x 20 x 1	25 x 25	10-5/8	10-5/8	1.015	150
KS-12	32	42	20	13.5	16	8	5.25	32.5	4- 20 x 25 x 1	31 x 31	12-5/8	12-5/8	1.440	220
KS-15	32	42	20	16	19	6.5	5.25	32.5	4- 20 x 25 x 1	31 x 31	15	15	2.010	220
KS-18	36	46	22	19	22	7	5.25	38.25	4- 20 x 28 x 1	35 x 35	18-1/8	18	2.870	310
KS-20	46	60	24	24.75	22.75	10.5	6	48	8- 20 x 20 x 1	45 x 45	20	18	3.880	540

Material: 18 gauge galvanized

Qty.	Model	CFM	SP	BHP	RPM	Motor Information				Tag
						HP	Volts	Phase	Enclosure	

Standard unit includes open drip NEMA frame ball bearing motor with adjustable V-drive mounted on rubber isolation; double width forward curved blower, and 1 inch washable aluminum filters. (All other type filters available.) Insulated hood is retained with quick release cover latches.

Options

- Aluminum Housing
- Painted Housing
- Paint Specifications:
- Alternate Filters: _____
- Other Modifications: _____
- Hinged Cover
- Motorized Damper Size _____ Voltage _____
- Locking Hasp
- Disconnect Switch
- (Damper and actuator are shipped loose for field mounting.)

To maintain KEES' policy of continuous product improvement, we reserve the right to change prices, specifications, ratings or dimensions without notice or obligation.

Project		Location	
Engineer		 KEES INCORPORATED 400 S. Industrial Dr. • P.O. Box L Elkhart Lake, WI 53020 Phone: (920) 876-3391 Fax: (920) 876-3065 Website: www.kees.com	
Architect			Dwg. No. SD-KS
Contractor			Date 08/06