

# MODEL IFG ROOF CURBS (SINGLE FURNACE)

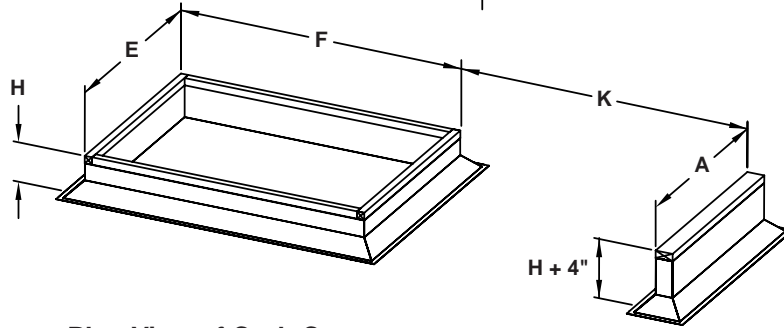

Plan View of Curb Cap

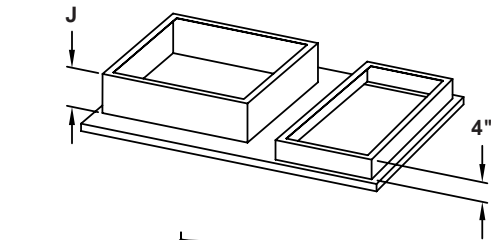
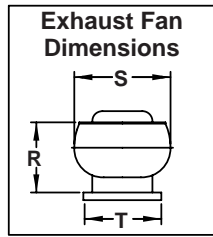
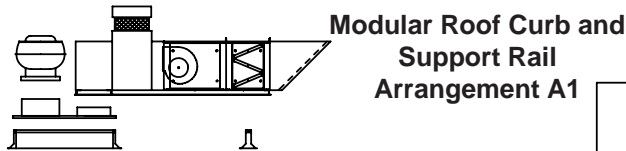
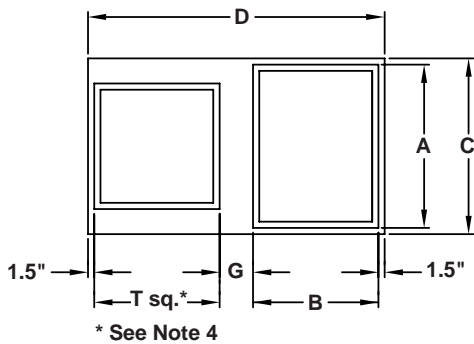

$C = A + 3" \text{ or } T + 3" \text{ (largest)}$   
 $D = B + G + T + 3"$   
 $E = C - 1"$   
 $F = D - 1"$   
 $G = \left(\frac{S-T}{2}\right) + 3"$   
 $J = 40" - H - R \text{ (4" min.)}$

Pitch - (1 or 2-way)

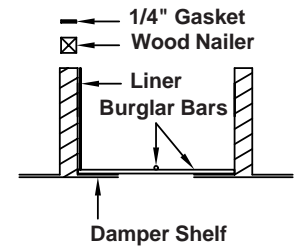
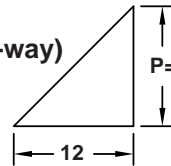

## Select One Roof Curb Model

Model #1



Model #3

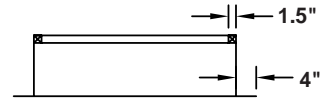

## Select One Housing Arrangement

Heater + Blower + Filter + Intake

H1

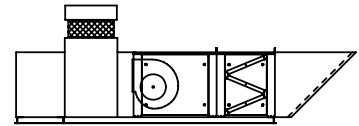

Heater + Blower + Intake with Filters

H2

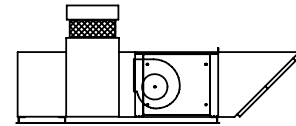

Housing	#1	#2 #2 Wide	#3
H1	K=82.75	K=91.25	K=107
H2	K=58.75	K=66.75	K=83

### OPTIONS:

- 07 Wood Nailer - Treated
- 10 Aluminum Construction
- 11 1/4" Neoprene Gasket
- 12 Inner Liner
- 16 One Way Pitch
- 17 Two Way Pitch
- 18 Burglar Bars
- 19 Damper Shelf

### NOTES:

1. Standard construction - 18 gauge galvanized with fiberglass insulation.
2. See reverse side for Curb Arrangements A2, A3 & A4.
3. Use above table to select dimension K.
4. Dimension T is the actual exhaust fan curb cap I.D.. KEES will undersize by 1/2".

Qty.	Fan Size (IFG)	Housing	A	B	C	D	E	F	G	H	J	K	Exhaust Fan Make & Model or R, S and T	Options	Tag
	-109/110	#1	31.50	23.50											
	-112/115	#2	39.50	23.50											
	-209/210	#2 Wide	51.00	23.50											
	-118/120	#3	51.00	23.50											

To maintain KEES' policy of continuous product improvement, we reserve the right to change prices, specifications, ratings or dimensions without notice or obligation.

<b>Project</b>		<b>Location</b>	
<b>Engineer</b>		<b>KEES INCORPORATED</b> 400 S. Industrial Dr. • P.O. Box L Elkhart Lake, WI 53020 Phone: (920) 876-3391 Fax: (920) 876-3065 Website: www.kees.com	
<b>Architect</b>			
<b>Contractor</b>			
<b>Dwg. No.</b>	SD-IFG-CURB-SF		
<b>Date</b>	03/06		

# MODEL IFG ROOF CURBS (SINGLE FURNACE)

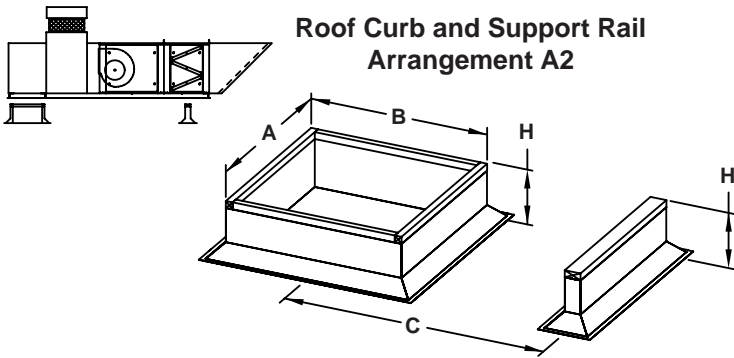

## Select One Roof Curb Model

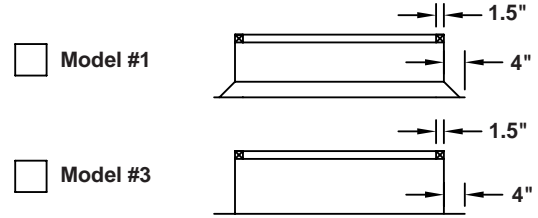

## Select One Housing Arrangement

Heater + Blower + Filter + Intake

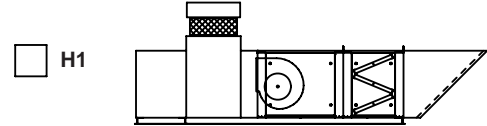

## Heater + Blower + Intake with Filters

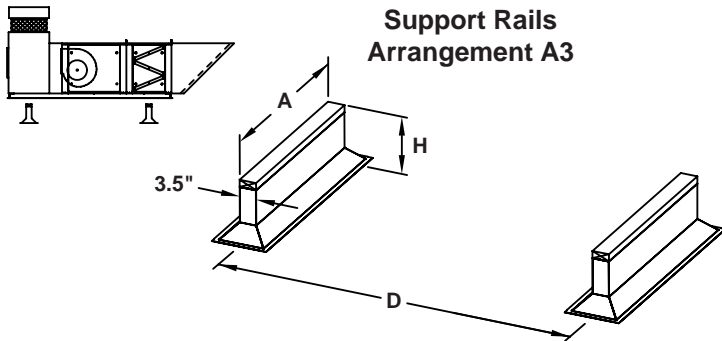
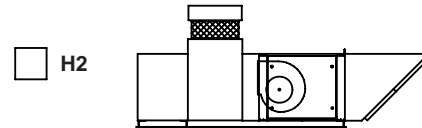

		Housing	#1	#2 #2 Wide	#3
H1	With Downturn	C	97.00	105.50	121.25
	With End Discharge	E	121.00	129.75	145.50
		D	72.00	80.50	96.25
H2	With Downturn	E	97.00	105.75	121.50
	With End Discharge	E	73.00	81.00	97.25
		E	93.00	101.00	117.25
	With End Discharge	D	48.00	56.00	72.25
		E	69.00	77.00	93.25

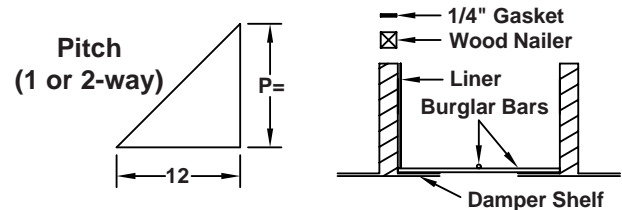
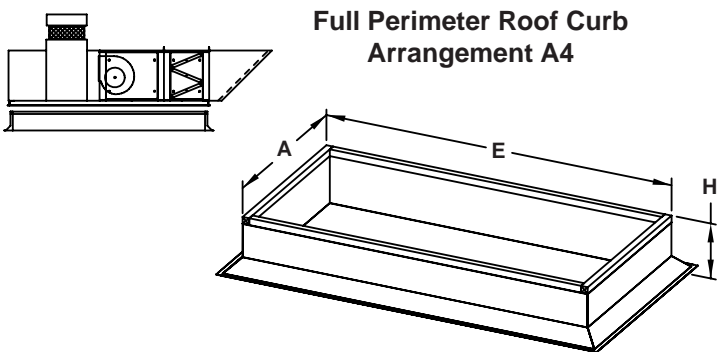

### OPTIONS:

- 07 Wood Nailer - Treated
- 10 Aluminum Construction
- 11 1/4" Neoprene Gasket
- 12 Inner Liner
- 16 One Way Pitch
- 17 Two Way Pitch
- 18 Burglar Bars
- 19 Damper Shelf

### NOTES:

1. Standard construction - 18 gauge galvanized with fiberglass insulation.
2. See reverse side for Curb Arrangement A1.
3. Use above table to select dimension C, D or E as needed.
4. Dimensions C and D are measured from the centerlines of the curb and rail.

Qty.	Fan Size (IFG)	Housing	Curb Arrangement A2				Curb Arrangement A3			Curb Arrangement A4			Options	Tag
			A	B	C	H	A	D	H	A	E	H		
	-109/110	#1	31.00	23.00			31.00			31.00				
	-112/115	#2	39.00	23.00			39.00			39.00				
	-209/210	#2 Wide	50.50	23.00			50.50			50.50				
	-118/120	#3	50.50	23.00			50.50			50.50				

To maintain KEES' policy of continuous product improvement, we reserve the right to change prices, specifications, ratings or dimensions without notice or obligation.

<b>Project</b>				<b>Location</b>			
<b>Engineer</b>							 <b>KEES INCORPORATED</b> 400 S. Industrial Dr. • P.O. Box L Elkhart Lake, WI 53020 Phone: (920) 876-3391 Fax: (920) 876-3065 Website: www.kees.com
<b>Architect</b>				<b>Dwg. No.</b>	SD-IFG-CURB-SF		
<b>Contractor</b>				<b>Date</b>	03/06		

# MODEL IFG ROOF CURBS (MULTIPLE FURNACES)

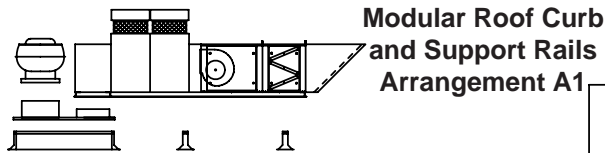

Modular Roof Curb and Support Rails Arrangement A1

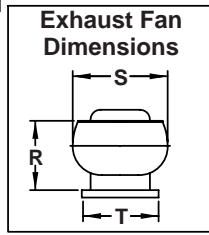

## Select One Roof Curb Model

Model #1

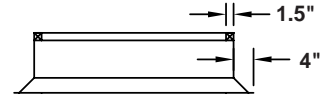

Model #3

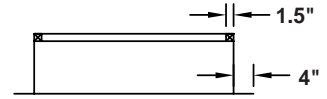

## Select One Housing Arrangement

Heaters + Blower + Filter + Intake

H1

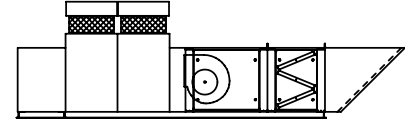

Heaters + Blower + Intake with Filters

H2

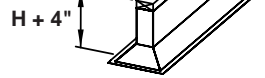
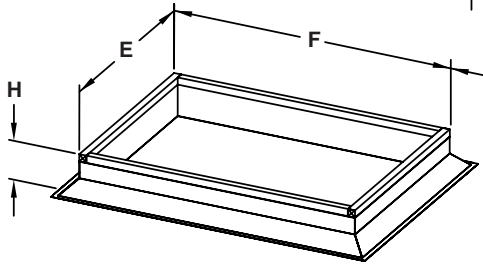
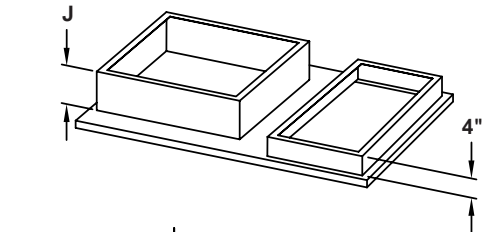
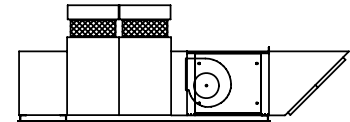

Plan View of Curb Cap

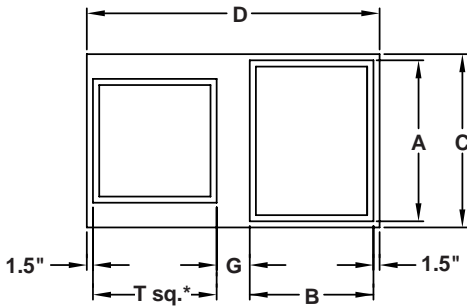

\* See Note 4

- C = A+3" or T+3" (largest)
- D = B+G+T+3"
- E = C-1"
- F = D-1"
- G =  $(\frac{S-T}{2})+3"$
- J = 40"-H-R (4" min.)

Housing	#2 #2 Wide	#3	#3
No. of Furnaces	2	2	3
H1	K=117.25	K=133	K=159
H2	K=92.75	K=109	K=135

Note: An additional support rail is recommended on units with Dimension "K" greater than 108".

## Pitch - (1 or 2-way)

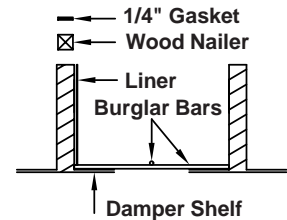
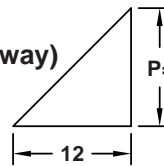

### OPTIONS:

- 07 Wood Nailer - Treated
- 10 Aluminum Construction
- 11 1/4" Neoprene Gasket
- 12 Inner Liner
- 16 One Way Pitch
- 17 Two Way Pitch
- 18 Burglar Bars
- 19 Damper Shelf

### NOTES:

1. Standard construction - 18 gauge galvanized with fiberglass insulation.
2. See reverse side for Curb Arrangements A2, A3 & A4.
3. Use above table to select dimension K.
4. Dimension T is the actual exhaust fan curb cap I.D.. KEES will undersize by 1/2".

Qty.	Fan Size (IFG)	Housing	A	B	C	D	E	F	G	H	J	K	Exhaust Fan Make & Model or R, S and T	Options	Tag
	-112/115	#2	39.50	23.50											
	-209/210	#2 Wide	51.00	23.50											
	-118/120	#3	51.00	23.50											

To maintain KEES' policy of continuous product improvement, we reserve the right to change prices, specifications, ratings or dimensions without notice or obligation.

<b>Project</b>		<b>Location</b>	
<b>Engineer</b>			
<b>Architect</b>		<b>Dwg. No.</b>	<b>SD-IFG-CURB-MF</b>
<b>Contractor</b>		<b>Date</b>	<b>03/06</b>



**KEES INCORPORATED**  
 400 S. Industrial Dr. • P.O. Box L  
 Elkhart Lake, WI 53020  
 Phone: (920) 876-3391  
 Fax: (920) 876-3065  
 Website: www.kees.com

# MODEL IFG ROOF CURBS (MULTIPLE FURNACES)

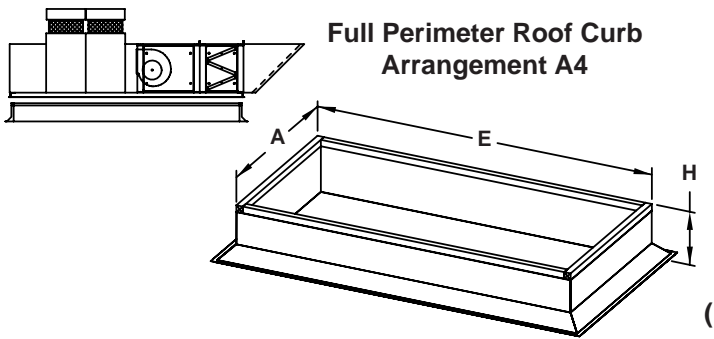
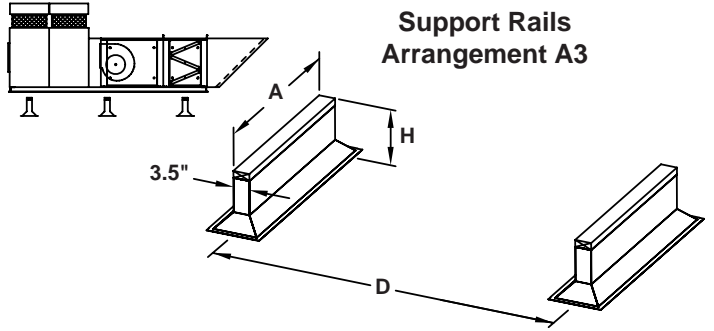
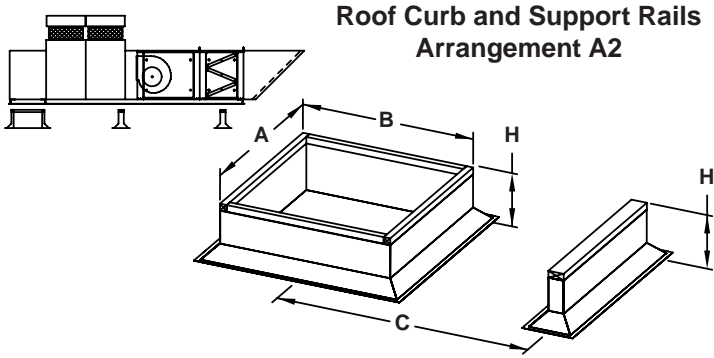

## Select One Roof Curb Model

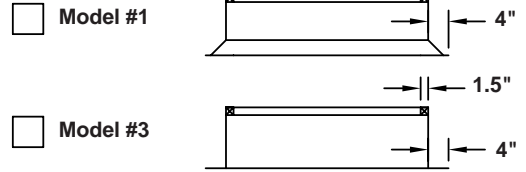

## Select One Housing Arrangement

Heaters + Blower + Filter + Intake

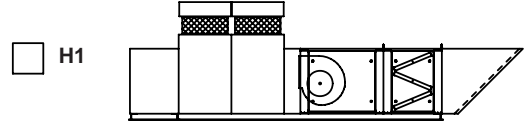

Heaters + Blower + Intake with Filters

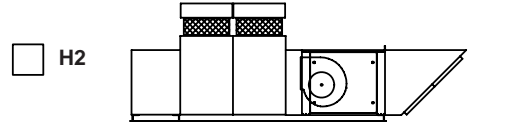

Housing		#2	#3	#3	
No. of Furnaces		#2 Wide	2	3	
H1	With	C	131.50	147.25	173.25
	Downturn	E	155.75	171.50	197.50
H1	With End	D	106.50	122.25	148.25
	Discharge	E	131.75	147.50	173.50
H2	With	C	107.00	123.25	149.25
	Downturn	E	127.00	143.25	169.25
H2	With End	D	82.00	98.25	124.25
	Discharge	E	103.00	119.25	145.25

Note: The additional support rail in the middle of the unit is only included when Dimension "C" or "D" is greater than 108".

Pitch  
(1 or 2-way)

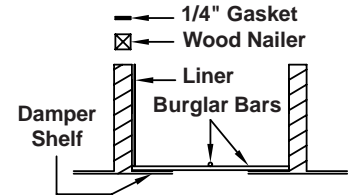
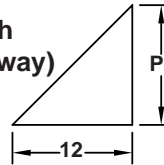

### OPTIONS:

- 07 Wood Nailer - Treated
- 10 Aluminum Construction
- 11 1/4" Neoprene Gasket
- 12 Inner Liner
- 16 One Way Pitch
- 17 Two Way Pitch
- 18 Burglar Bars
- 19 Damper Shelf

### NOTES:

1. Standard construction - 18 gauge galvanized with fiberglass insulation.
2. See reverse side for Curb Arrangement A1.
3. Use above table to select dimension C, D or E as needed.
4. Dimensions C and D are measured from the centerlines of the curb and rail.

Qty.	Fan Size (IFG)	Housing	Curb Arrangement A2				Curb Arrangement A3			Curb Arrangement A4			Options	Tag
			A	B	C	H	A	D	H	A	E	H		
	-112/115	#2	39.00	23.00			39.00			39.00				
	-209/210	#2 Wide	50.50	23.00			50.50			50.50				
	-118/120	#3	50.50	23.00			50.50			50.50				

To maintain KEES' policy of continuous product improvement, we reserve the right to change prices, specifications, ratings or dimensions without notice or obligation.

<b>Project</b>				<b>Location</b>			
<b>Engineer</b>							 <b>KEES INCORPORATED</b> 400 S. Industrial Dr. • P.O. Box L Elkhart Lake, WI 53020 Phone: (920) 876-3391 Fax: (920) 876-3065 Website: www.kees.com
<b>Architect</b>				<b>Dwg. No.</b>	SD-IFG-CURB-MF		
<b>Contractor</b>				<b>Date</b>	03/06		