

# MODEL FRK - U.L. CLASSIFIED FIRE RATED DIFFUSER AIR DISTRIBUTION SUBMITTAL

- NOTES:**
- Galvanized steel construction
  - Outlet end painted flat black

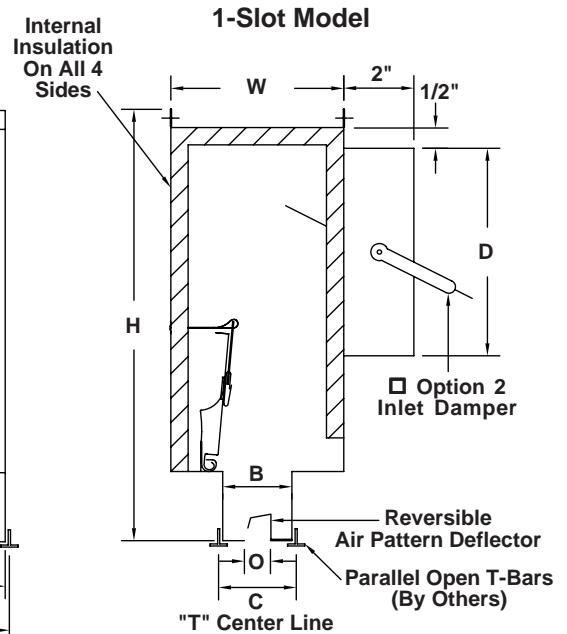
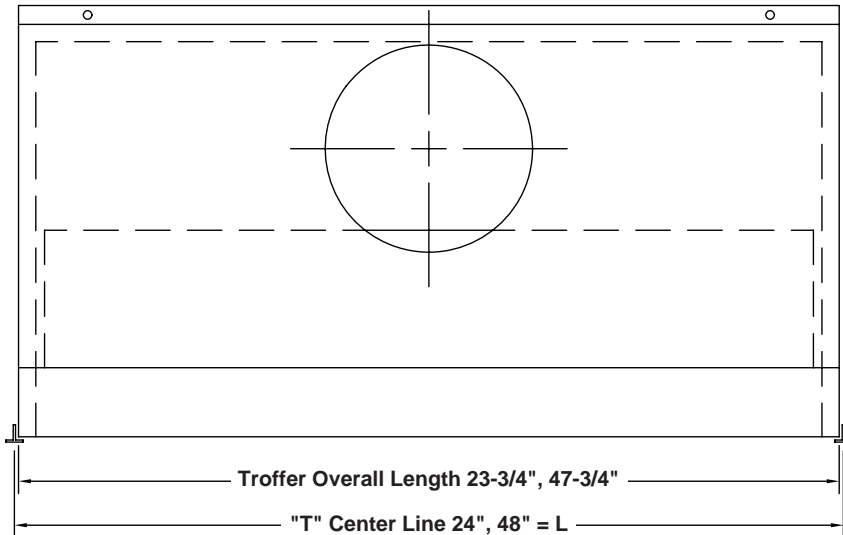

SUGGESTED INLET SIZES	H
UP TO 125 CFM - 5" RD. INLET	12-1/2
100 TO 175 CFM - 6" RD. INLET	12-1/2
150 TO 250 CFM - 7" RD. INLET	12-1/2
250 TO 350 CFM - 8" RD. INLET	12-1/2
350 TO 450 CFM - 9" RD. INLET	12-1/2
450 TO 600 CFM - 10" OV. INLET	12-1/2

Model Nos.	Slot Width O	W	B	C
FRK-75-1	3/4	5	2-1/4	2-1/2
FRK-100-1	1	5	2-1/2	2-3/4
FRK-150-1	1-1/2	5	3	3-1/4

**NOTE:** Side tees must be provided as part of approved grid system.

**NOTE:** Diffuser must be supported from ceiling structure independent of grid system.

**Material:** 22 gauge steel.

**Finish:** Diffuser face and air pattern deflector flat black.

Underwriters Laboratories, Inc. © Classified Air Terminal Units Category BZGU. For use in exposed grid suspended ceiling in floor-ceiling designs with 3 hour or less restrained or unrestrained assembly rating. Consult the U.L. Fire Resistance Directory for further details regarding U.L. Classified floor-ceiling designs.

Quantity	Model	Length "L"	Height "H"	Inlet Size "D"	Damper	Options	Tag

To maintain KEES' policy of continuous product improvement, we reserve the right to change prices, specifications, ratings or dimensions without notice or obligation.

<b>Project</b>				<b>Location</b>			
<b>Engineer</b>							
<b>Architect</b>				<b>Dwg. No.</b>	SD-FRK-1		
<b>Contractor</b>				<b>Date</b>	05/07		



**KEES INCORPORATED**  
 400 S. Industrial Dr. • P.O. Box L  
 Elkhart Lake, WI 53020  
 Phone: (920) 876-3391  
 Fax: (920) 876-3065  
 Website: www.kees.com

# MODEL FRK - U.L. CLASSIFIED FIRE RATED DIFFUSER AIR DISTRIBUTION SUBMITTAL

- NOTES:**
- Galvanized steel construction
  - Outlet end painted flat black

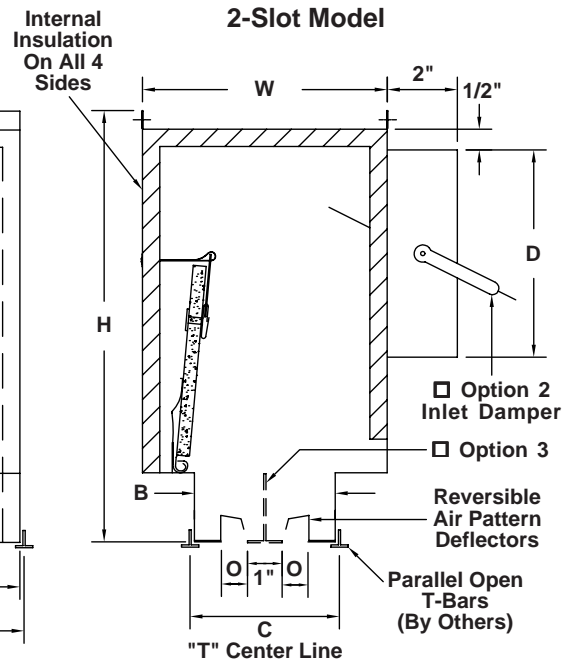
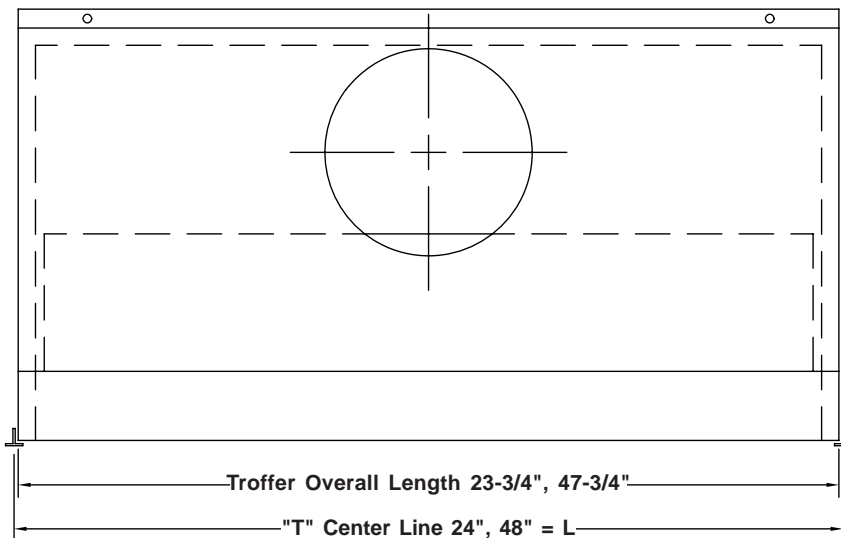

SUGGESTED INLET SIZES	H
UP TO 125 CFM - 5" RD. INLET	12-1/2
100 TO 175 CFM - 6" RD. INLET	12-1/2
150 TO 250 CFM - 7" RD. INLET	12-1/2
250 TO 350 CFM - 8" RD. INLET	12-1/2
350 TO 450 CFM - 9" RD. INLET	12-1/2
450 TO 600 CFM - 10" OV. INLET	12-1/2

Model Nos.	Slot Width O	W	B	C
FRK-75-2	3/4	7-1/8	4-1/8	4-3/8
FRK-100-2	1	7-1/8	4-1/8	4-3/8
FRK-150-2	1-1/2	7-1/8	5-1/8	5-3/8

## ACCESSORY OPTIONS

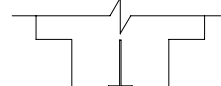

Option 3  
Factory installed Center T  
(2 way opposite or same  
way throw)



Option 4  
Slot provided in ends to fit astride  
ceiling grid T-bar (by others)  
(2 way opposite throw only)

**NOTE:** Side tees must be provided as part of approved grid system.

**NOTE:** Diffuser must be supported from ceiling structure independent of grid system.

Material: 22 gauge steel.

Finish: Diffuser face and air pattern deflector flat black.

Underwriters Laboratories, Inc. ® Classified Air Terminal Units Category BZGU. For use in exposed grid suspended ceiling in floor-ceiling designs with 3 hour or less restrained or unrestrained assembly rating. Consult the U.L. Fire Resistance Directory for further details regarding U.L. Classified floor-ceiling designs.

Quantity	Model	Length "L"	Height "H"	Inlet Size "D"	Damper	Options	Tag

To maintain KEES' policy of continuous product improvement, we reserve the right to change prices, specifications, ratings or dimensions without notice or obligation.

<b>Project</b>				<b>Location</b>			
<b>Engineer</b>							
<b>Architect</b>			<b>Dwg. No.</b>	<b>SD-FRK-2</b>			
<b>Contractor</b>			<b>Date</b>	<b>05/07</b>			



**KEES INCORPORATED**  
400 S. Industrial Dr. • P.O. Box L  
Elkhart Lake, WI 53020  
Phone: (920) 876-3391  
Fax: (920) 876-3065  
Website: www.kees.com