



DUCT ACCESS DOORS FOR FIBERGLASS DUCT WORK

STANDARD SIZES

Quantity		Ductboard Thickness	Size	Dim. A Width	Dim. B Height	Frame Neck O.D.	Cams ADC	Cams ADH
ADC-DF	ADH-DF							
			6 x 6	6	6	4-7/8" x 4-7/8"	2	1
			8 x 8	8	8	6-7/8" x 6-7/8"	2	
			10 x 10	10	10	8-7/8" x 8-7/8"	2	1
			12 x 12	12	12	10-7/8" x 10-7/8"	2	1
			14 x 14	14	14	12-7/8" x 12-7/8"	2	1
			16 x 16	16	16	14-7/8" x 14-7/8"	4	2
			18 x 18	18	18	16-7/8" x 16-7/8"	4	2
			20 x 20	20	20	18-7/8" x 18-7/8"	4	
			24 x 24	24	24	22-7/8" x 22-7/8"	4	2
			24 x 36	24	36	22-7/8" x 34-7/8"	6	3

SPECIFICATIONS:

- DOOR PANEL:
24 gauge galvanized steel
- FRAME:
22 gauge galvanized steel
- INSULATION:
1" fiberglass
- PRE-FORMED TABS:
30 gauge galvanized steel

* OPTIONAL CONSTRUCTION:

- Sleeve for 1-1/2" ductboard
- Sleeve for 2" ductboard

Check if look-thru type view port is wanted. Yes No

**TYPICAL DOUBLE PANEL
ACCESS DOOR**

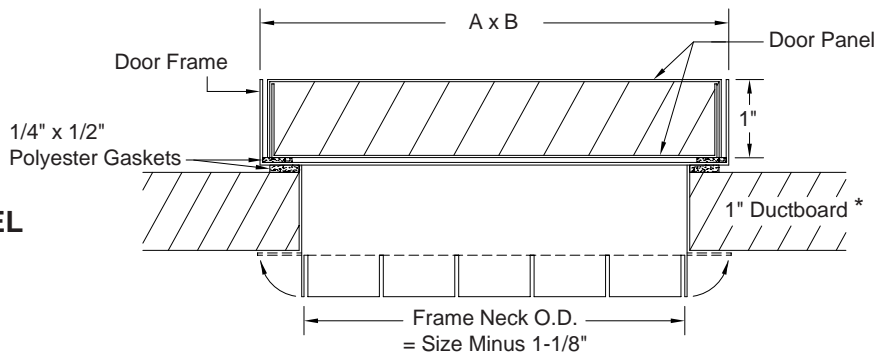

To maintain KEES' policy of continuous product improvement, we reserve the right to change prices, specifications, ratings or dimensions without notice or obligation.

Project		Location		
Engineer				
Architect		Dwg. No.	SD-AD-F	
Contractor		Date	03/04	

KEES INCORPORATED
 400 S. Industrial Dr. • P.O. Box L
 Elkhart Lake, WI 53020
 Phone: (920) 876-3391
 Fax: (920) 876-3065
 Website: www.kees.com