

STANDARD SIZES

Quantity		Size	Dim. A Width	Dim. B Height	Frame Neck O.D.	Cams ADC-D2	Cams ADH-D2
ADC-D2	ADH-D2						
		6 x 6	6	6	4-7/8" x 4-7/8"	2	1
		8 x 8	8	8	6-7/8" x 6-7/8"	2	1
		10 x 10	10	10	8-7/8" x 8-7/8"	2	1
		12 x 12	12	12	10-7/8" x 10-7/8"	2	1
		14 x 14	14	14	12-7/8" x 12-7/8"	2	1
		16 x 16	16	16	14-7/8" x 14-7/8"	4	2
		18 x 18	18	18	16-7/8" x 16-7/8"	4	2
		20 x 20	20	20	18-7/8" x 18-7/8"	4	2
		24 x 24	24	24	22-7/8" x 22-7/8"	4	2
		24 x 36	24	36	22-7/8" x 34-7/8"	6	3

SPECIFICATIONS:

- DOOR PANEL:
24 gauge galvanized steel
- FRAME:
22 gauge galvanized steel
- INSULATION:
2" fiberglass
- PRE-FORMED TABS:
22 gauge galvanized steel

Standard construction to 4.5" S.P.

TYPICAL DOUBLE PANEL ACCESS DOOR

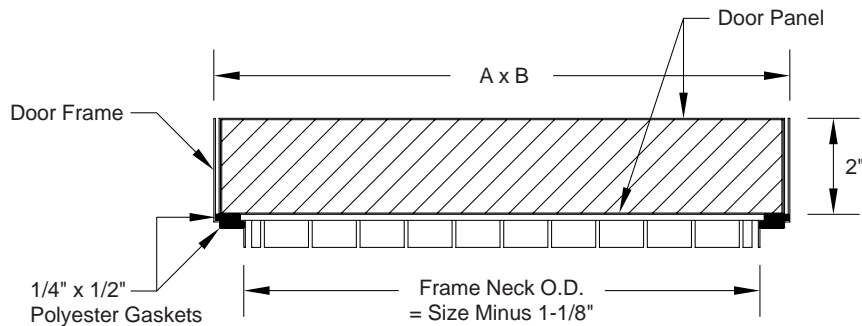

To maintain KEES' policy of continuous product improvement, we reserve the right to change prices, specifications, ratings or dimensions without notice or obligation.

Project		Location	
Engineer			
Architect		Dwg. No.	SD-ADC-2
Contractor		Date	01/06



KEES INCORPORATED
 400 S. Industrial Dr. • P.O. Box L
 Elkhart Lake, WI 53020
 Phone: (920) 876-3391
 Fax: (920) 876-3065
 Website: www.kees.com