

MODEL 250 AIR BASEBOARD

STANDARD SIZES IN ONE SECTION

- 24" Long x 8" High x 4" Wide
- 36" Long x 8" High x 4" Wide
- 48" Long x 8" High x 4" Wide
- 60" Long x 8" High x 4" Wide
- 72" Long x 8" High x 4" Wide
- 96" Long x 8" High x 4" Wide

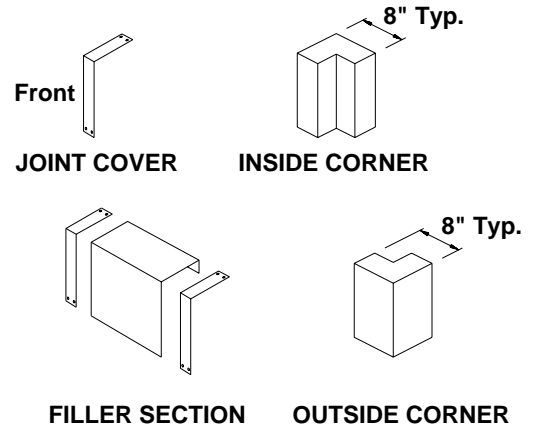
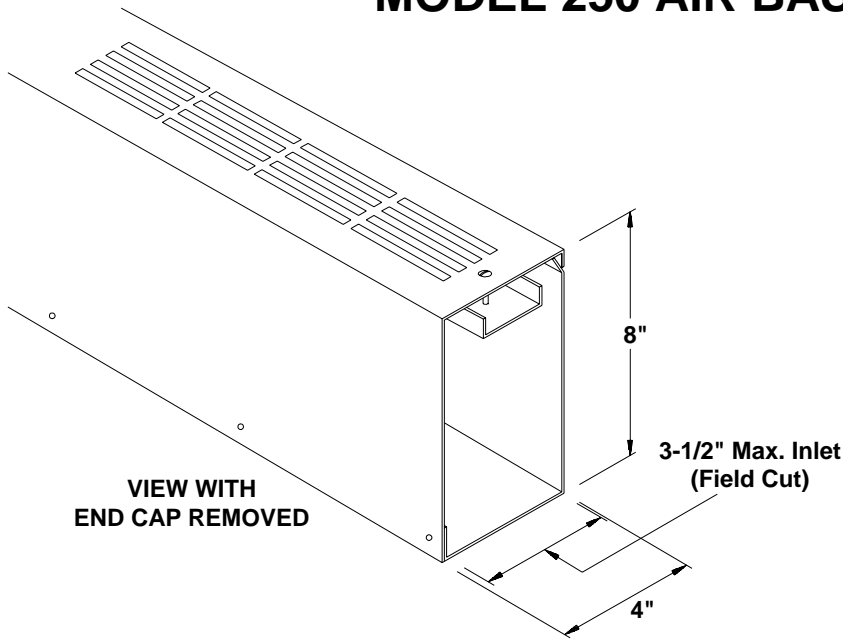

Every section includes cap on each end integral with back/bottom.

CONSTRUCTION: Easily adjustable full length damper provides for an even discharge along the entire length of the cabinet as well as air quantity control. Baseboard is of two piece construction: 18 GA. galvanealed top, front, and end section, and 20 GA. galvanized back and bottom - both sections being joined by Phillips head fasteners. Air outlets of 3 inch by 1/4 inch slots provide draftless distribution. Inlet openings are field cut.

STANDARD FINISH: Tan.

Qty.	Length	Number of Joint Covers	Filler Sections	Inside Corner	Outside Corner	Finish	Special	Tag

To maintain KEES' policy of continuous product improvement, we reserve the right to change prices, specifications, ratings or dimensions without notice or obligation.

Project		Location		 KEES INCORPORATED 400 S. Industrial Dr. □ P.O. Box L Elkhart Lake, WI 53020 Phone: (920) 876-3391 Fax: (920) 876-3065 Website: www.kees.com
Engineer		Dwg. No.	AB	
Architect		Date	02-02	
Contractor				