

Motor Control Center

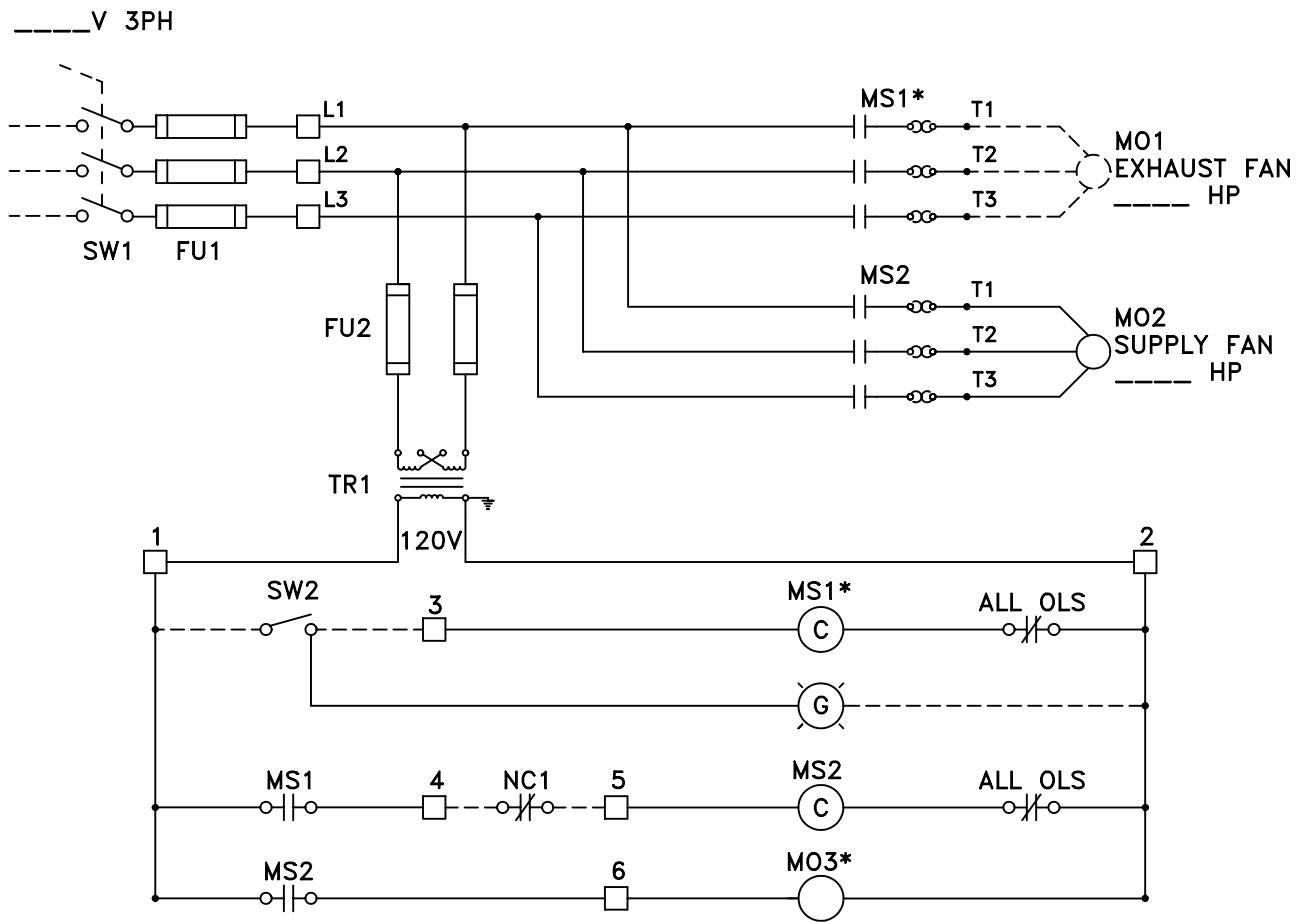

----- DENOTES FIELD WIRING

** BY OTHERS
* OPTIONAL

** FU1 = MAIN FUSES
FU2 = CONTROL FUSES
** M01 = EXHAUST FAN MOTOR
M02 = SUPPLY FAN MOTOR
* M03 = DAMPER MOTOR (S.F.)
* MS1 = EXHAUST FAN MOTOR STARTER
MS2 = SUPPLY FAN MOTOR STARTER
** NC1 = NC CONTACT (FIRE SUPP. SYS.)
SW1 = DOOR INTERLOCK DISC. SWITCH
TR1 = CONTROL TRANSFORMER

MOUNTING OPTIONS:

- INDOOR MOUNTING NEMA 1 PANEL
DOOR INTERLOCK DISCONNECT
- OUTDOOR MOUNTING NEMA 3R PANEL
RAINTIGHT SAFETY SWITCH

NOTE: REMOVE JUMPER FROM TERMINAL BLOCKS 4 & 5 AFTER INSTALLING NC1

PROJECT				 <p>KEES INCORPORATED 400 S. INDUSTRIAL ROAD ELKHART LAKE, WI 53020 PHONE:(920)876-3391 FAX:(920)876-3065</p>
LOCATION		DWG. NO.		
REP.		DATE		