

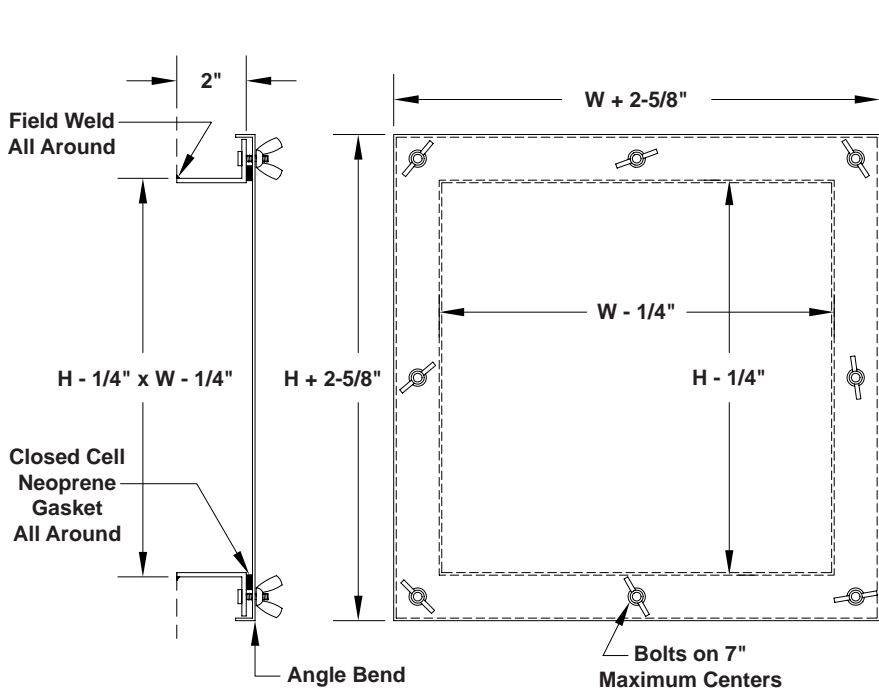

# ULTRA HIGH PRESSURE DUCT ACCESS DOORS

**Features:**

- 14 GA. Welded Galvanized Steel Construction (Electro-Galvanized Frame, Galvanized Cover)
- Optional 16 GA. 304 S.S. Construction
- Finish - Mill
- Rated For Up To 20" W.G. Positive Or Negative Pressure



**FLAT DUCT MODEL UHPA**

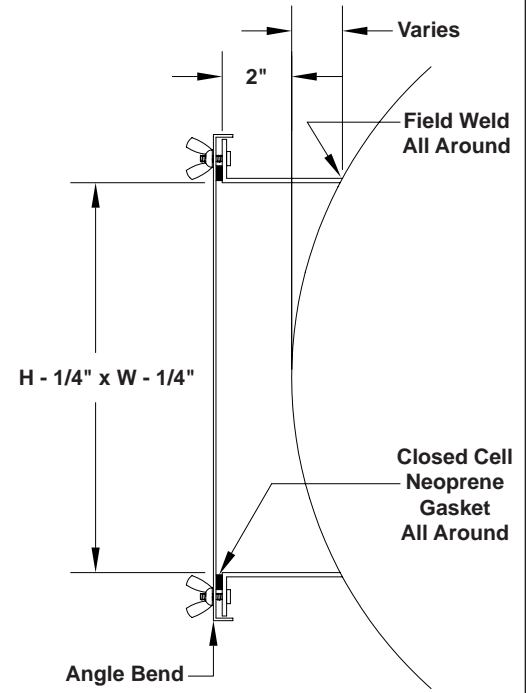

**ROUND DUCT MODEL UHPA-R**

Qty.	Model	W	H	Duct Diameter	Material		Tag
					Steel	S.S.	

To maintain KEES' policy of continuous product development, we reserve the right to change prices, specifications, ratings and dimensions without notice or obligation.

Project				Location			
Engineer				Dwg. No.	SD-UHPA		
Architect				Date	07/11		
Contractor							



**KEES INCORPORATED**  
 400 S. Industrial Dr. • P.O. Box L  
 Elkhart Lake, WI 53020  
 Phone: (920) 876-3391  
 Fax: (920) 876-3065  
 Website: www.kees.com