

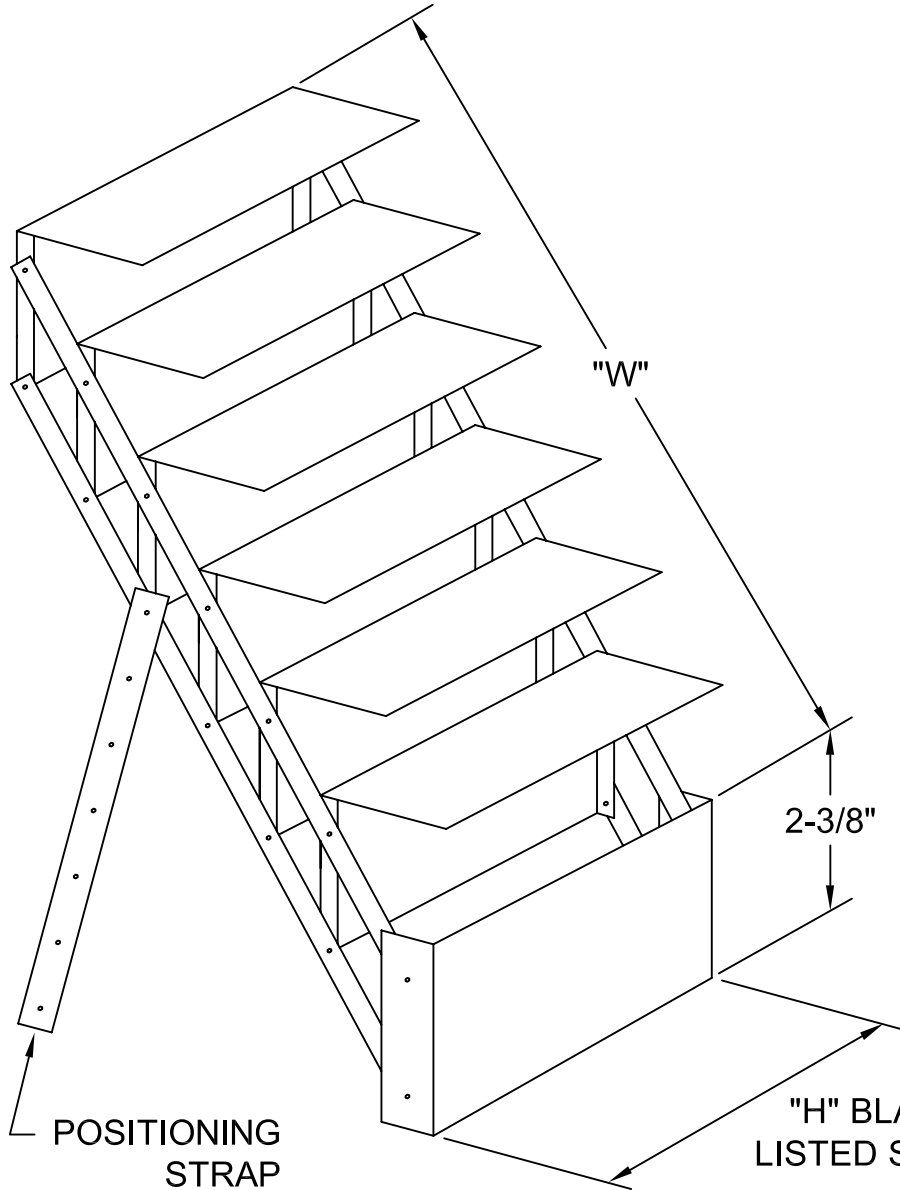

STAINLESS STEEL EXTRACTOR

TYPE 304 (STANDARD) OR 316 (OPTIONAL) WITH MILL FINISH



No. of Blades	Actual Width "W"
1	2.875"
2	4.875"
3	6.875"
4	8.875"
5	10.875"
6	12.875"
7	14.875"
8	16.875"
9	18.875"
10	20.875"
11	22.875"
12	24.875"
13	26.875"
14	28.875"
15	30.875"
16	32.875"
17	34.875"
18	36.875"
19	38.875"
20	40.875"

Qty.	Type Steel		Listed Size		No. of Blades	Actual Size		Tag
	304	316	W	H		W	H	

To maintain KEES' policy of continuous product improvement, we reserve the right to change prices, specifications, ratings or dimensions without notice or obligation.

Project				Location			
Engineer				Dwg. No. SD-SSXTR		KEES INCORPORATED 400 S. Industrial Dr. Elkhart Lake, WI 53020 Phone: (920) 876-3391 Fax: (920) 876-3065 Website: www.kees.com	
Architect			Date 10/07				
Contractor							