

# STAINLESS STEEL PERFORATED GRILLES - SSPG

## 304 (Standard) or 316 (Optional) Stainless - Satin Finish

20 GA. Frame, 20 GA. Perforated Face  
 Maximum single section 60" x 48". Sizes larger than 60" x 48" available.  
 Available options include: opposed blade damper or plaster frame.  
 See reverse side for butting details on multiple piece grilles.

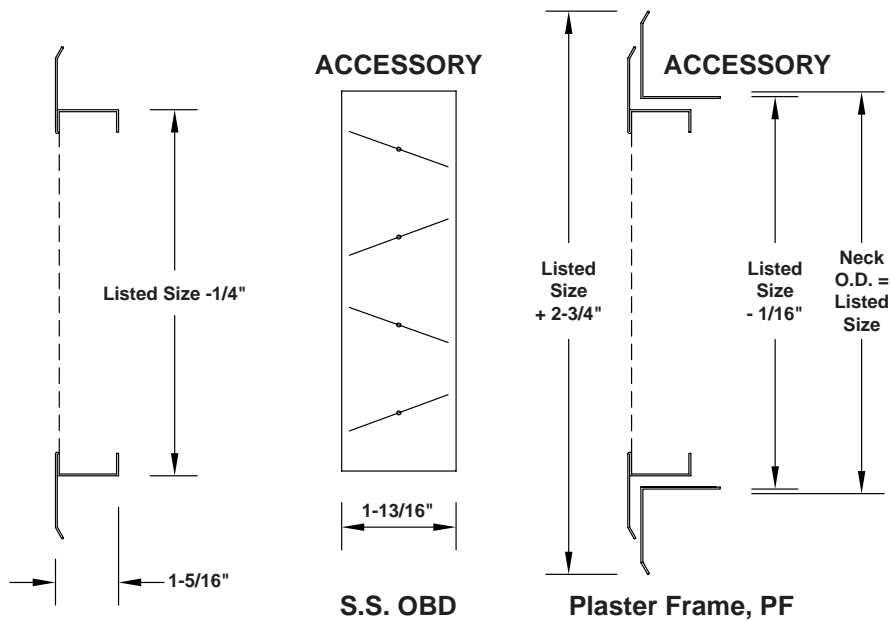
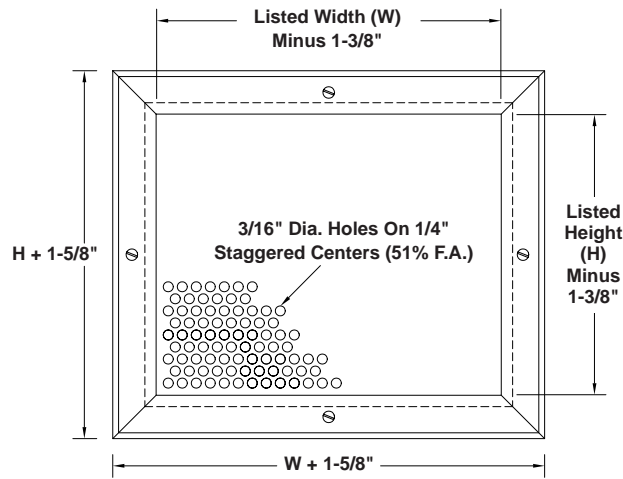

Qty.	Model	W	H	Type S.S.		Plaster Frame	Tag
				Grille	O.B.D.		

To maintain KEES' policy of continuous product improvement, we reserve the right to change prices, specifications, ratings or dimensions without notice or obligation.

<b>Project</b>				<b>Location</b>			
<b>Engineer</b>							
<b>Architect</b>			<b>Dwg. No.</b>	<b>SD-SSPG</b>			
<b>Contractor</b>			<b>Date</b>	<b>08/09</b>			



**KEES INCORPORATED**  
 400 S. Industrial Dr. • P.O. Box L  
 Elkhart Lake, WI 53020  
 Phone: (920) 876-3391  
 Fax: (920) 876-3065  
 Website: www.kees.com

# STAINLESS STEEL PERFORATED GRILLES - SSPG

## 304 or 316 Stainless - Satin Finish

20 GA. Frame, 20 GA. Blades

Maximum single piece size for double deflection grille is 48" x 48".  
 Maximum single piece size for single deflection grille is 60" x 48" or 48" x 60".  
 Larger order sizes will be made in multiple individual sections to fit opening size.  
 Mullion supports within opening to be provided by others.

### BUTTING DETAIL

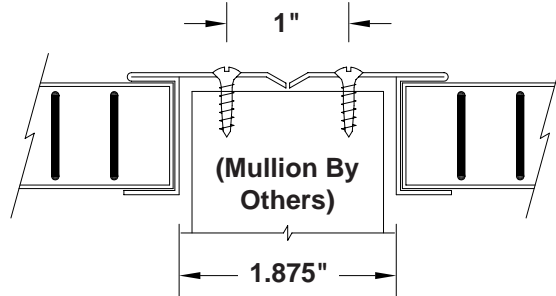

#### SINGLE DEFLECTION

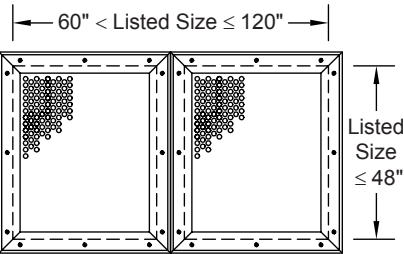

#### SINGLE DEFLECTION

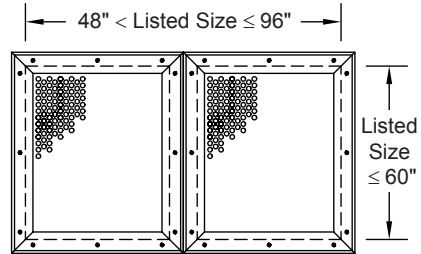

OR

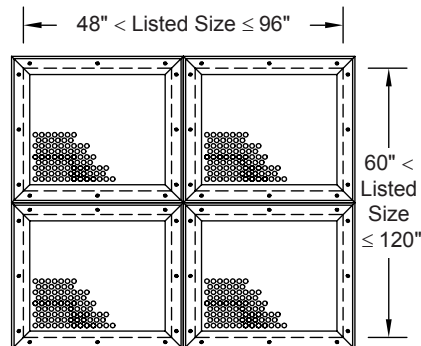
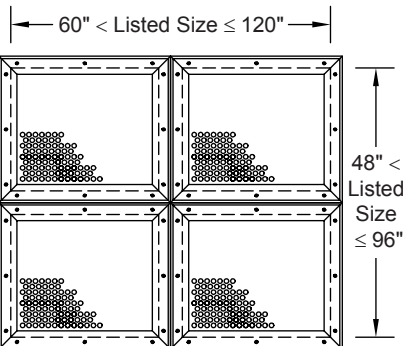

OR

To maintain KEES' policy of continuous product improvement, we reserve the right to change prices, specifications, ratings or dimensions without notice or obligation.

<b>Project</b>		<b>Location</b>	
<b>Engineer</b>			
<b>Architect</b>	<b>Dwg. No.</b>	<b>SD-SSPG</b>	 <b>KEES INCORPORATED</b> 400 S. Industrial Dr. • P.O. Box L Elkhart Lake, WI 53020 Phone: (920) 876-3391 Fax: (920) 876-3065 Website: www.kees.com
<b>Contractor</b>	<b>Date</b>	<b>08/09</b>	



# MODEL SSRG Stainless Steel Perforated Face Return Grilles

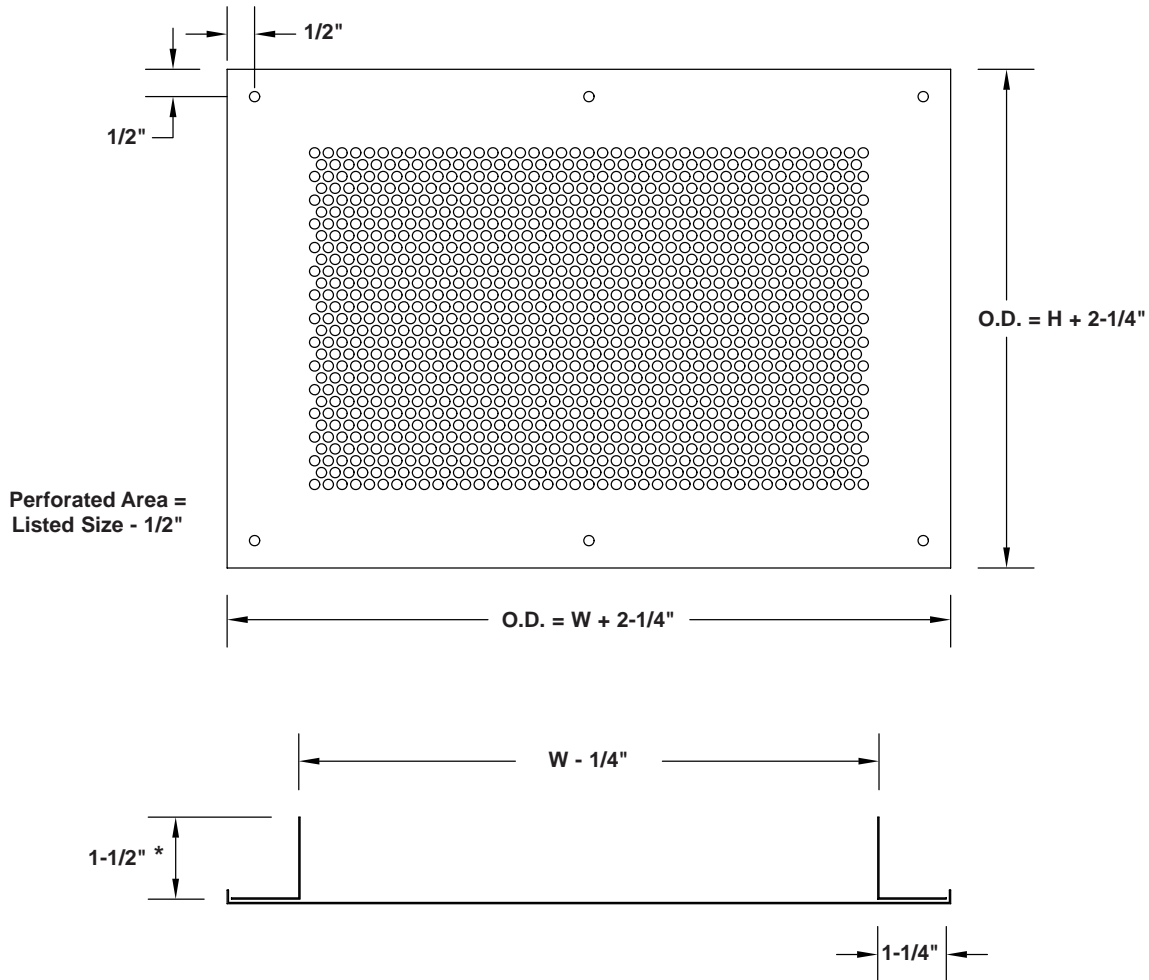

MATERIAL: 20 GA. Stainless Steel With Satin Polished Finish. Type 304 (Standard) or 316 (Optional).

3/16" Dia. Holes On 1/4" Staggered Centers.

Screw Holes For #8 Pan Head Phillips Screws.

Optional Damper Of Steel, 304 S.S. (Standard) or 316 S.S. (Optional).

\* 3" With Optional O.B.D.

Qty.	W	H	Grille		O.B.D.		Finish	Tag
			304 S.S.	316 S.S.	304 S.S.	316 S.S.		

To maintain KEES' policy of continuous product improvement, we reserve the right to change prices, specifications, ratings or dimensions without notice or obligation.

<b>Project</b>				<b>Location</b>			
<b>Engineer</b>					<b>KEES INCORPORATED</b> 400 S. Industrial Dr. • P.O. Box L Elkhart Lake, WI 53020 Phone: (920) 876-3391 Fax: (920) 876-3065 Website: www.kees.com		
<b>Architect</b>			<b>Dwg. No.</b>	<b>SD-SSRG</b>			
<b>Contractor</b>			<b>Date</b>	<b>08/06</b>			