



OVERHEAD INDUSTRIAL HOODS



TYPICAL USES:

Venting heated or lighter than air vapors and gases of all types, and fine dusts that are air suspended.

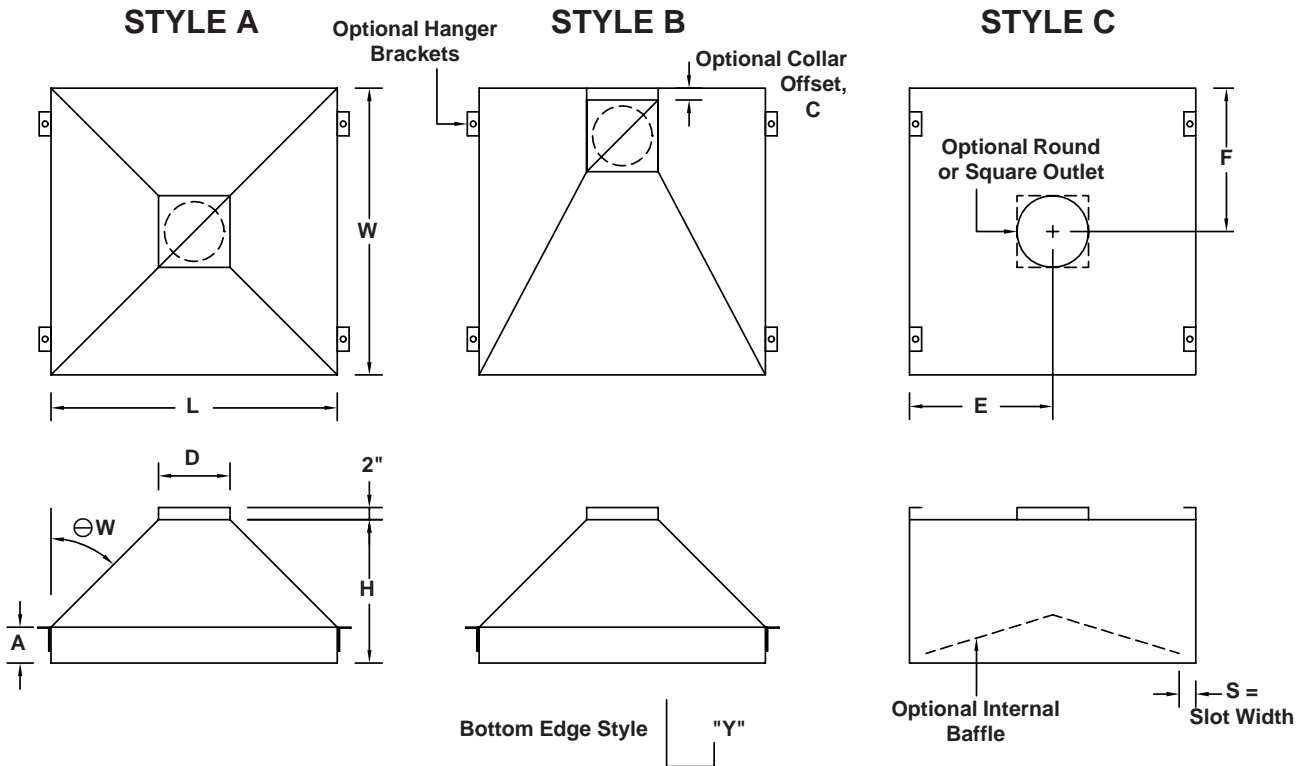

CONSTRUCTION: All welded 18 GA. galvanized steel, 18 GA. 304 or 316 stainless steel with 2B finish or .063 aluminum. Heavier gauges available: 16, 14, 12 and 10.

DIMENSIONS: As required for job conditions.

| Qty. | Style | Material | Gauge | L | W | H | A | Nominal D | Actual O.D. / I.D. | Offset C | Location E | Location F |
|------|-------|----------|-------|---|---|---|---|-----------|--------------------|----------|------------|------------|
| | | | | | | | | | | | | |
| | | | | | | | | | | | | |

| "S" Slot Width | Hanger Brackets | $\ominus L$ | $\ominus W$ | Finish | Special | Tag |
|----------------|-----------------|-------------|-------------|--------|---------|-----|
| | | | | | | |
| | | | | | | |

To maintain KEES' policy of continuous product improvement, we reserve the right to change prices, specifications, ratings or dimensions without notice or obligation.

| | | | |
|-------------------|--|-----------------|----------------|
| Project | | Location | |
| Engineer | | | |
| Architect | | Dwg. No. | SD-SMOH |
| Contractor | | Date | 08/07 |



KEES INCORPORATED
 400 S. Industrial Dr. • P.O. Box L
 Elkhart Lake, WI 53020
 Phone: (920) 876-3391
 Fax: (920) 876-3065
 Website: www.kees.com