

# EXTRUDED ALUMINUM AIR DIFFUSER FRAMES

## OPTION #12

(Shown as used with KEES K-slot Diffuser - OPTION #12 also available sized for use with any lay-in diffuser)

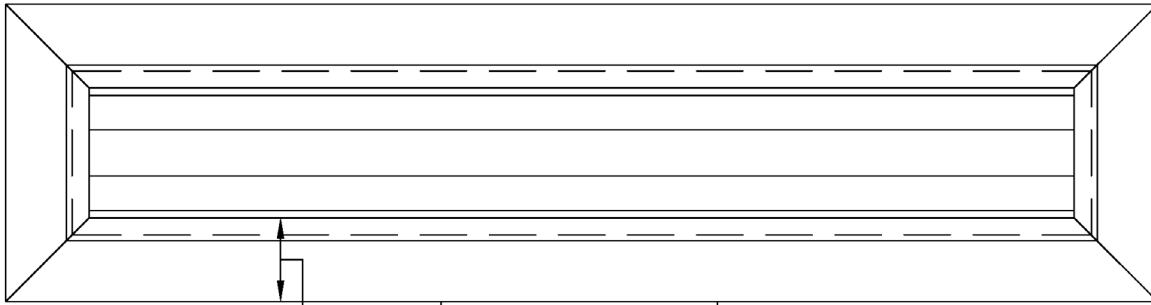

1-11/16"

**BOTTOM VIEW**

### OPTION #12

#### FRAME CONSTRUCTION:

.060-6063-T6 Extruded aluminum

#### FASTENING METHOD:

Concealed self-tapping screws fastened thru slot opening

#### FINISH:

Off-white

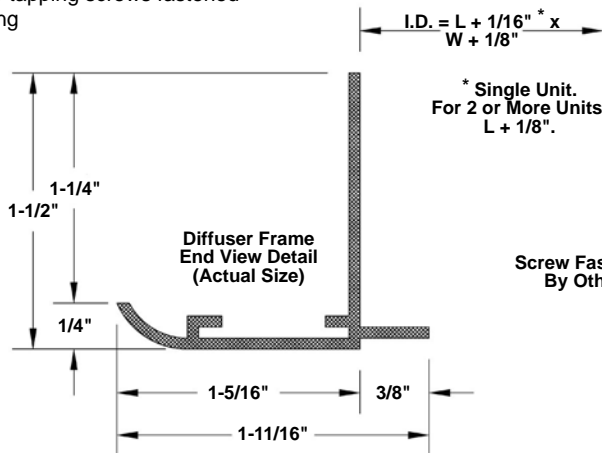

W = WIDTH OF PLENUM

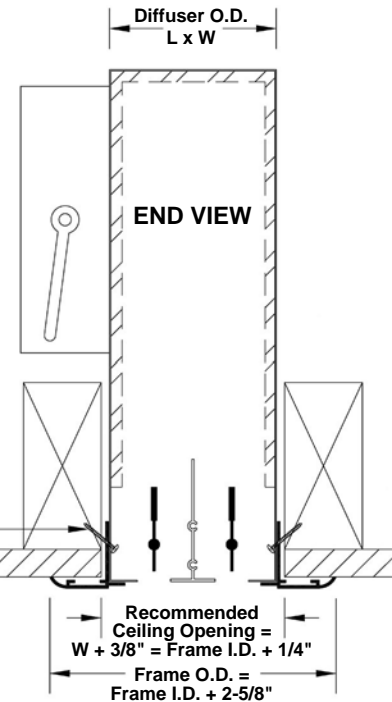

	FRAME I.D. = W + 1/8"		FRAME I.D. = W + 1/8"		FRAME I.D. = W + 1/8"		FRAME I.D. = W + 1/8"
K-50-1	1-3/4"	K-75-1	2"	K-100-1	2-1/4"	K-150-1	2-3/4"
KLP-50-1	1-3/4"	KLP-75-1	2"	KLP-100-1	2-1/4"	KLP-150-1	2-3/4"
KR-50-1	1-3/4"	KR-75-1	2"	KR-100-1	2-1/4"	KR-150-1	2-3/4"
K-50-2	3-1/4"	K-75-2	3-3/4"	K-100-2	4-1/4"	K-150-2	5-1/4"
KLP-50-2	3-1/4"	KLP-75-2	3-3/4"	KLP-100-2	4-1/4"	KLP-150-2	5-1/4"
KR-50-2	3-1/4"	KR-75-2	3-3/4"	KR-100-2	4-1/4"	KR-150-2	5-1/4"
K-50-3	4-3/4"	K-75-3	5-1/2"	K-100-3	6-1/4"	K-150-3	7-3/4"
KR-50-3	4-3/4"	KR-75-3	5-1/2"	KR-100-3	6-1/4"	KR-150-3	7-3/4"
K-50-4	6-1/4"	K-75-4	7-1/4"	K-100-4	8-1/4"	K-150-4	10-1/4"
KR-50-4	6-1/4"	KR-75-4	7-1/4"	KR-100-4	8-1/4"	KR-150-4	10-1/4"
K-50-6	9-1/4"	K-75-6	10-3/4"	K-100-6	12-1/4"	K-150-6	15-1/4"
K-50-8	12-1/4"	K-75-8	14-1/4"	K-100-8	16-1/4"	K-150-8	20-1/4"
K-50-10	15-1/4"	K-75-10	17-3/4"	K-100-10	20-1/4"	K-150-10	25-1/4"

To maintain KEES' policy of continuous product development, we reserve the right to change prices, specifications, ratings and dimensions without notice or obligation.

Project	Location	
Engineer	Dwg. No.	SD-OPT. 12
Architect	Date	03/04
Contractor		



**KEES INCORPORATED**  
 400 S. Industrial Dr.  
 Elkhart Lake, WI 53020  
 Phone: (920) 876-3391  
 Fax: (920) 876-3065  
 Website: www.kees.com

# EXTRUDED ALUMINUM AIR DIFFUSER FRAMES

## OPTION #12-SF

(For use with any lay-in diffuser or grille)

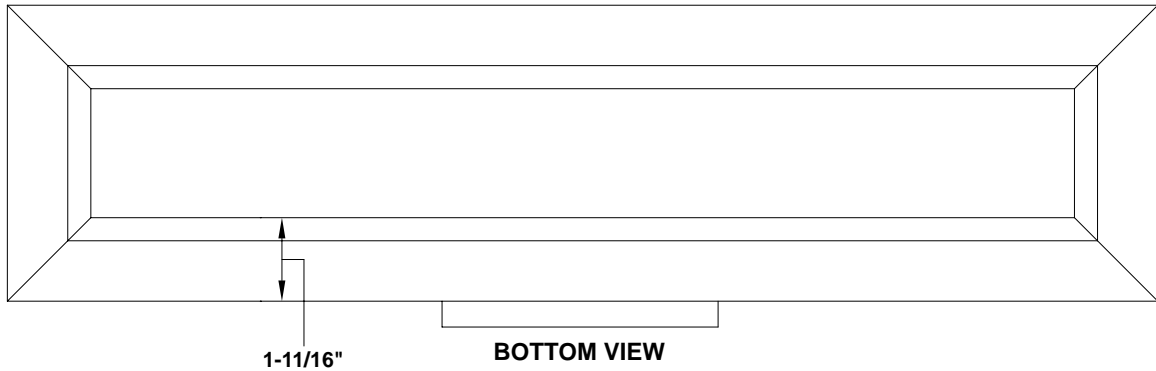

### OPTION #12

**FRAME CONSTRUCTION:**

.060-6063-T6 Extruded aluminum

**FASTENING METHOD:**

Concealed self-tapping screws fastened thru slot opening

**FINISH:**

Off-white

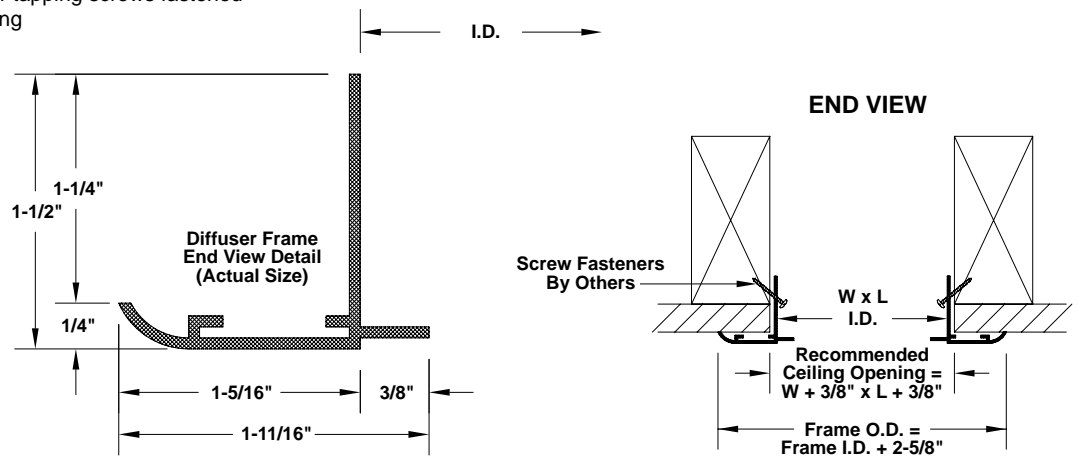

QTY.	FRAME I.D.		TAG
	L	W	

To maintain KEES' policy of continuous product development, we reserve the right to change prices, specifications, ratings and dimensions without notice or obligation.

<b>Project</b>			<b>Location</b>		
<b>Engineer</b>			 <b>KEES INCORPORATED</b> 400 S. Industrial Dr. Elkhart Lake, WI 53020 Phone: (920) 876-3391 Fax: (920) 876-3065 Website: www.kees.com	<b>Dwg. No.</b>	<b>SD- OPT. 12-SF</b>
<b>Architect</b>				<b>Date</b>	<b>03/04</b>
<b>Contractor</b>					