

SEG-9RD SECURITY GRILLE — ROUND SLEEVE

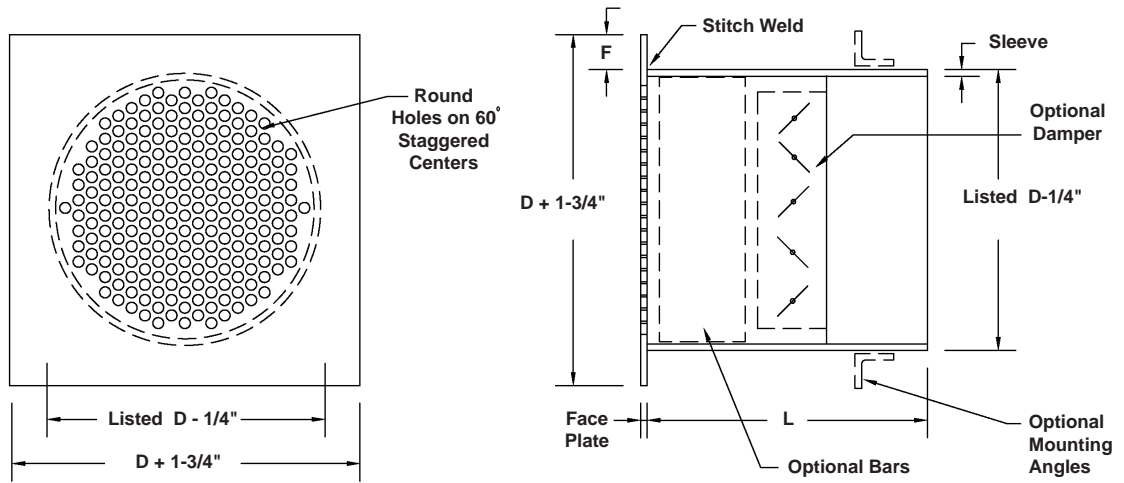

STANDARD CONSTRUCTION

Face: 3/16" thick steel square face stitch welded to sleeve. 1" face flange.
Hole Pattern: 5/16" diameter holes on 7/16" staggered centers.
Sleeve: 10 ga. steel with continuously welded or formed seams.
Finish: Two part polyurethane inside and out. White.

REQUIRED CONSTRUCTION:

- Face Shape:** Square (Std.)
 Round
- Face Material:** 3/16" steel (Std.)
 10 ga. steel
 Other _____
- Hole Pattern:** 5/16" dia. holes on 7/16" centers (Std.)
 1/4" dia. holes on 3/8" centers
 Other _____
- Flange "F":** 1" (Std.)
 Other _____
- Sleeve Material:** 10 ga. steel (Std.)
 3/16" steel (not available for some sizes)
 12 ga. steel
 Other _____
- Finish:** White (Std.)
 Other _____
- Other Material:** SEG-9RDA all aluminum
 SEG-9RDSS all stainless steel (Consult factory for available thickness')

MOUNTING OPTIONS:

- 11A.** Two loose pieces of 1" x 1" x 3/16" mill finish steel angle loose for field welding. Length equal to flange o.d. of grille. Other angle size _____
- 11B.** Rear angle frame (square) of 1" x 1" x 3/16" mill finish steel completely assembled for field welding. Other angle size _____
- 11R.** Rear angle ring for field welding to sleeve. Mill finish steel . Angle size varies by diameter.
to 5" dia. 1" x 1" x 1/8"
6" to 11" dia. 1-1/4" x 1-1/4" x 1/8"
12" to 15" dia. 1-1/2" x 1-1/2" x 1/8"
16" to 24" dia. 1-1/2" x 1-1/2" x 3/16"
25" to 48" dia. 2" x 2" x 3/16"
- 23.** Masonry anchors: 1/2" x 3" Anchors 16" o.c., four per grille minimum, welded to sleeve exterior. Other size or spacing _____
- 25.** Countersunk screw holes in face 10" o.c. with #10 x 1-1/2" long Torx security sheet metal screws. Other screw length _____

ACCESSORIES:

- 16F.** Face operated opposed blade damper tack welded into sleeve. Damper is square with blankoff. Dampers are adjustable using flat bladed screwdriver.
- 16R.** Rear operated opposed blade damper tack welded into sleeve. Damper is square with blankoff. Dampers are adjustable using flat bladed screwdriver.
- 21.** 2-1/2" x 3/8" hot rolled steel vertical security bars 4" o.c., welded to sleeve.
- Other:** _____

Qty.	Listed Size Diameter	Sleeve O.D. Diameter	Masonry Opening Diameter	Sleeve Length L	Wall/Ceiling Thickness	Accessories	Mounting Option	Tag

To maintain KEESS' policy of continuous product improvement, we reserve the right to change prices, specifications, ratings or dimensions without notice or obligation.

Project		Location	
Architect / Engineer		Contractor	
Representative		Dwg. No.	SEG-9RDw 04/20/10
		Date	

KEES INCORPORATED
Elkhart Lake, WI 53020
Phone: (920) 876-3391
Fax: (920) 876-3065
Website: www.kees.com