

SEG-6P SECURITY GRILLE — SUPPLY OR RETURN

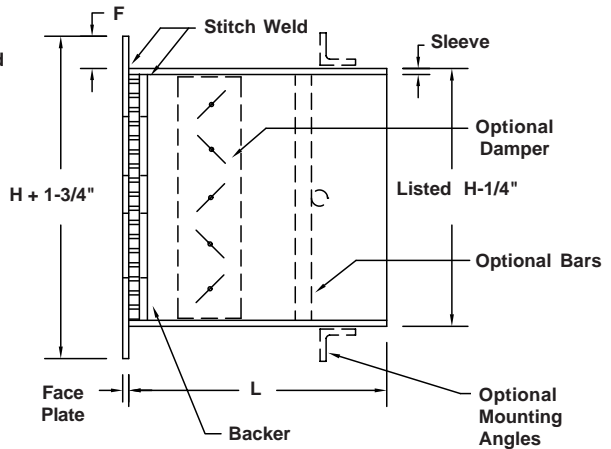
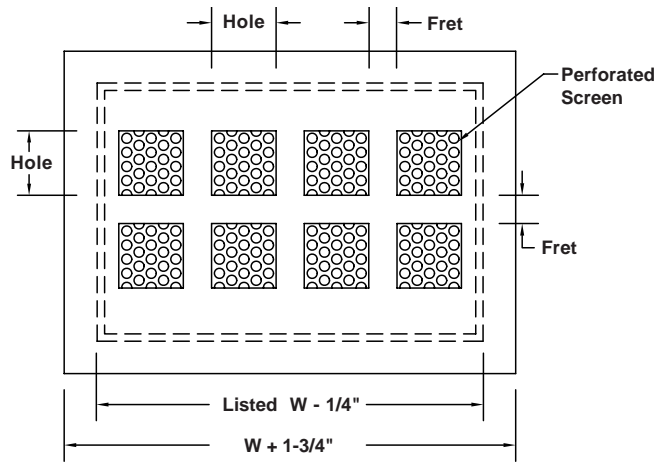

STANDARD CONSTRUCTION

Face: 3/16" thick steel stitch welded to sleeve. 1" face flange.
Hole Pattern: 2" x 2" holes with 1" frets *.
Perforated Plate: 3/16" thick steel with 3/16" dia holes on 9/32" staggered centers.
Sleeve: 3/16" steel with continuously welded or formed seams.
Finish: Two part polyurethane inside and out. White.

REQUIRED CONSTRUCTION:

- Face Material:** 3/16" steel (Std.)
 Other _____
- Backer Material:** 3/16" thick steel (Std.)
 Other _____
- Hole Pattern:** 2" x 2" holes with 1/2" frets (Std.)
 2" x 2" holes with 1" frets*
 Other _____
- Perf. Plate:** 3/16" steel with 3/16" dia. holes on 9/32" staggered centers.(Std.)
 10 ga. steel with 1/8" dia. holes on 3/16" staggered centers.
 16 ga. steel with 3/32" dia. holes on 5/32" staggered centers.
 Other _____
- Flange "F":** 1" (Std.)
 Other _____
- Sleeve Material:** 3/16" steel (Std.)
 Other _____
- Finish:** White (Std.)
 Other _____

MOUNTING OPTIONS:

- 11A.** Two loose pieces of 1" x 1" x 3/16" mill finish steel angle loose for field welding. Length equal to longest side of grille. Other angle size _____
- 11B.** Rear angle frame of 1" x 1" x 3/16" mill finish steel completely assembled for field welding. Other angle size _____
- 12A.** Rear angle frame for bolting to sleeve. 1" x 1" x 3/16" steel with bolt holes 8" o.c. for 1/4" dia. bolts. No holes in sleeve. No bolts, nuts or washers. Other angle size _____
- 12B.** Rear angle frame for bolting to sleeve. 1" x 1" x 3/16" steel with bolt holes in sleeve and frame 8" o.c. for 1/4" dia. bolts. No bolts, nuts or washers. (Advise wall or ceiling thickness). Other angle size _____
- 23.** Masonry anchors: 1/2" x 3" anchors 16" o.c., one per side minimum, welded to sleeve exterior. Other size or spacing _____
- 24.** Countersunk screw holes in face 10" o.c. with #10-24 x 2" long Torx security machine screws for maximum 1-1/2" ceiling thickness. 1" x 1" x 1/8" steel angle frame with matching holes and foldover nuts. Requires 1-1/2" flange.
- 25.** Countersunk screw holes in face 10" o.c. with #10 x 1-1/2" long Torx security sheet metal screws. Other screw size or length _____

ACCESSORIES:

- 16F.** Face operated opposed blade damper tack welded into sleeve.
- 16R.** Rear operated opposed blade damper tack welded into sleeve.
- 19.** 1/2" dia. A-36 mild steel security bars 6" o.c. both ways, welded to sleeve and at intersections.
- Other:** _____

* Frets may be reduced to 7/8" to allow additional holes.

Qty.	Listed Size		Sleeve O.D.		Masonry Opening		Sleeve Length L	Wall Thickness	Accessories	Mounting Option	Tag
	W	H	W	H	W	H					

To maintain KEES' policy of continuous product improvement, we reserve the right to change prices, specifications, ratings or dimensions without notice or obligation.

Project		Location		
Architect / Engineer		<p>KEES INCORPORATED 400 S. Industrial Dr. • P.O. Box L Elkhart Lake, WI 53020 Phone: (920) 876-3391 Fax: (920) 876-3065 Website: www.kees.com</p>		
Contractor			Dwg. No.	SEG-6PW 03/29/06
Representative			Date	