

SEG-4 SECURITY GRILLE — SUPPLY OR RETURN

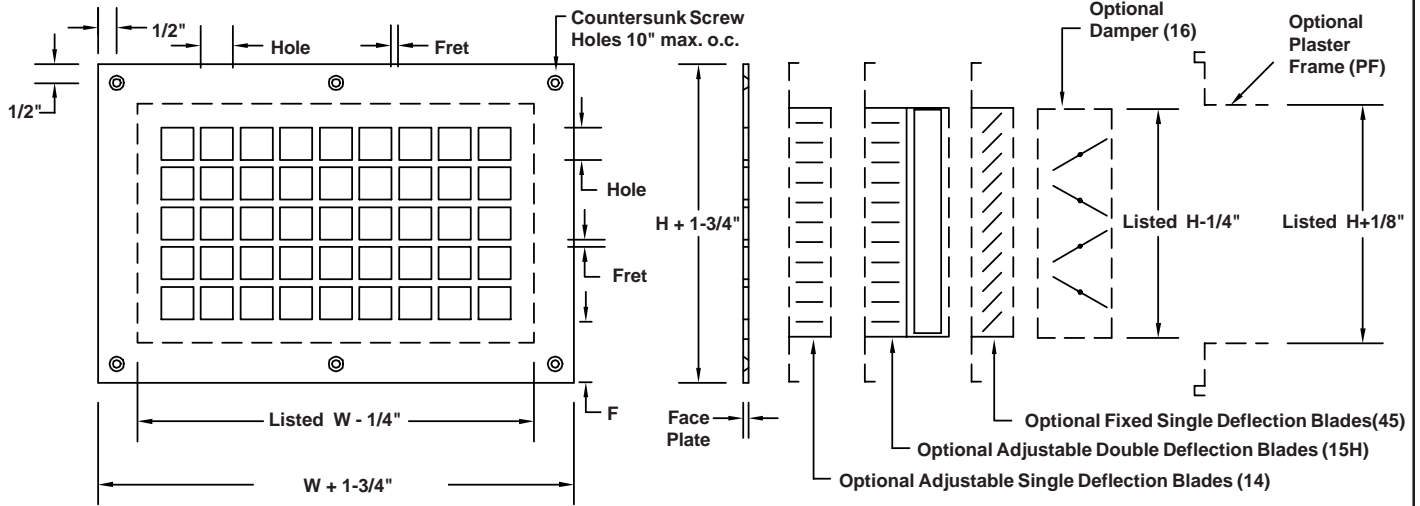

STANDARD CONSTRUCTION

Face: 12 ga. steel. 1" minimum face flange.
Hole Pattern: 13/16" square holes with 3/16" frets.
Finish: Two part polyurethane inside and out. White.

REQUIRED CONSTRUCTION:

- Face Material:**
- 12 ga. steel (Std.)
 - 14 ga. steel
 - 10 ga. steel
 - 3/16" steel
 - Other _____
- Hole Pattern:**
- 13/16" square holes with 3/16" frets. (Std.)
 - 3/4" square holes with 1/4" frets.
 - 1/2" square holes with 3/16" frets.
 - Other _____
- Flange "F":**
- 1" (Std.)
 - Other _____
- Finish:**
- White (Std.)
 - Other _____
- Other Material:**
- SEG-4A** all aluminum construction 1/8" thick.
 - SEG-4SS** all stainless steel construction 12 ga. type 304.

MOUNTING OPTIONS:

- 25.** (Std) Countersunk screw holes in face 10" o.c. with #10 x 1-1/2" long Torx security sheet metal screws. Other screw style/size/length _____
- 24.** Countersunk screw holes in face 10" o.c. with #10-24 x 2" long Torx security machine screws for 1-1/2" maximum ceiling thickness. 1" x 1" x 1/8" steel angle frame with matching holes and foldover nuts. Requires 1-1/2" flange.

ACCESSORIES:

- 13.** Commercial single deflection grille with adjustable vertical blades.
- 14.** Commercial single deflection grille with adjustable horizontal blades.
- 15H.** Commercial double deflection grille with adjustable blades, horizontal front and vertical rear.
- 15V.** Commercial double deflection grille with adjustable blades, vertical front and horizontal rear.
- 16F.** Face operated opposed blade damper tack welded to face or attached to grille.
- 30.** Commercial single deflection grille with vertical fixed blades at 0 degrees.
- 40.** Commercial single deflection grille with horizontal fixed blades at 0 degrees.
- 45.** Commercial single deflection grille with horizontal fixed blades at 45 degrees.
- PF.** Commercial plaster frame (Frame o.d. = listed size + 1/8").
- Other Options:** _____

Qty.	Listed Size		Accessory O.D.		Masonry Opening		Accessories	Damper	Mounting Option	Tag
	W	H	W	H	W	H				

To maintain KEES' policy of continuous product improvement, we reserve the right to change prices, specifications, ratings or dimensions without notice or obligation.

Project		Location		
Architect / Engineer				
Contractor		Dwg. No.	SEG-4W 03/29/06	<p>KEES INCORPORATED 400 S. Industrial Dr. • P.O. Box L Elkhart Lake, WI 53020 Phone: (920) 876-3391 Fax: (920) 876-3065 Website: www.kees.com</p>
Representative		Date		

SEG-4P SECURITY GRILLE – SUPPLY OR RETURN

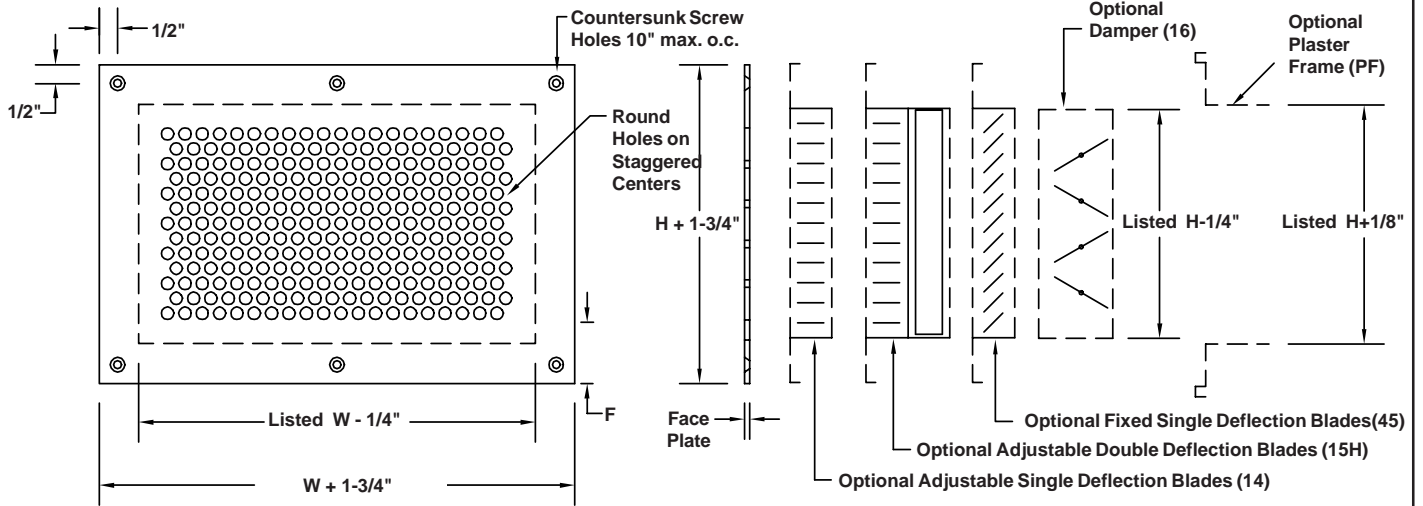

STANDARD CONSTRUCTION

Face: 12 ga. steel. 1" minimum face flange.
Hole Pattern: 5/16" round holes on 7/16" staggered centers.
Finish: Two part polyurethane inside and out. White.

REQUIRED CONSTRUCTION:

- Face Material:**
- 12 ga. steel (Std.)
 - 14 ga. steel
 - 10 ga. steel
 - 3/16" steel
 - Other _____
- Hole Pattern:**
- 5/16" round holes on 7/16" staggered centers. (Std.)
 - 1/4" round holes on 3/8" staggered centers.
 - 3/16" round holes on 9/32" staggered centers (limited sizes and material).
 - Other _____
- Flange "F":**
- 1" (Std.)
 - Other _____
- Finish:**
- White (Std.)
 - Other _____
- Other Material:**
- SEG-4PA** all aluminum construction 1/8" thick.
 - SEG-4PSS** all stainless steel construction 12 ga. type 304.

MOUNTING OPTIONS:

- 25.** (Std) Countersunk screw holes in face 10" o.c. with #10 x 1-1/2" long Torx security sheet metal screws. Other screw style/size/length _____
- 24.** Countersunk screw holes in face 10" o.c. with #10-24 x 2" long Torx security machine screws for 1-1/2" maximum ceiling thickness. 1" x 1" x 1/8" steel angle frame with matching holes and foldover nuts. Requires 1-1/2" flange.

ACCESSORIES:

- 13.** Commercial single deflection grille with adjustable vertical blades.
- 14.** Commercial single deflection grille with adjustable horizontal blades.
- 15H.** Commercial double deflection grille with adjustable blades, horizontal front and vertical rear.
- 15V.** Commercial double deflection grille with adjustable blades, vertical front and horizontal rear.
- 16F.** Face operated opposed blade damper tack welded to face or attached to grille.
- 30.** Commercial single deflection grille with vertical fixed blades at 0 degrees.
- 40.** Commercial single deflection grille with horizontal fixed blades at 0 degrees.
- 45.** Commercial single deflection grille with horizontal fixed blades at 45 degrees.
- PF.** Commercial plaster frame (Frame o.d. = listed size + 1/8").
- Other Options:** _____

Qty.	Listed Size		Accessory O.D.		Masonry Opening		Accessories	Damper	Mounting Option	Tag
	W	H	W	H	W	H				

To maintain KEES' policy of continuous product improvement, we reserve the right to change prices, specifications, ratings or dimensions without notice or obligation.

Project		Location		
Architect / Engineer				
Contractor		Dwg. No.	SEG-4PW 03/29/06	<p>KEES INCORPORATED 400 S. Industrial Dr. • P.O. Box L Elkhart Lake, WI 53020 Phone: (920) 876-3391 Fax: (920) 876-3065 Website: www.kees.com</p>
Representative		Date		

SEG-4P3 SECURITY GRILLE – SUPPLY OR RETURN

Complies with NIC recommendations and California BoP Title 24

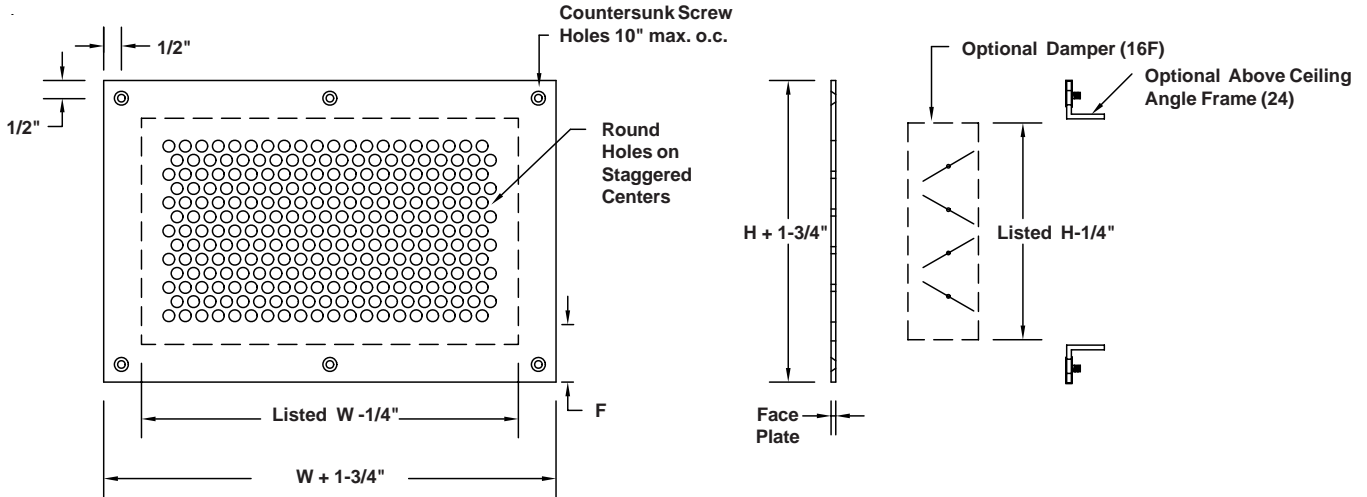

STANDARD CONSTRUCTION

Face: 14 ga. steel. 1" minimum face flange.
Hole Pattern: 3/16" round holes on 9/32" staggered centers.
Finish: Two part polyurethane inside and out. White.

REQUIRED CONSTRUCTION:

- Face Material:** 14 ga. steel (Std.)
 12 ga. steel (limited sizes)
 10 ga. steel (limited sizes)
 Other _____
- Hole Pattern:** 3/16" round holes on 9/32" staggered centers. (Std.)
 5/32" round holes on 7/32" staggered centers. (SEG-4P5)
 Other _____
- Flange "F":** 1" (Std.)
 Other _____
- Finish:** White (Std.)
 Other _____
- Other Material:** **SEG-4P3A** all aluminum construction 1/8" thick.
 SEG-4P3SS all stainless steel construction 14 ga. type 304.

MOUNTING OPTIONS:

- 25.** (Std) Countersunk screw holes in face 10" o.c. with #10 x 1-1/2" long Torx security sheet metal screws.
 Other screw style/size/length _____
- 24.** Countersunk screw holes in face 10" o.c. with #10-24 x 2" long Torx security machine screws. 1" x 1" x 1/8" steel angle frame with matching holes and foldover nuts. Requires 1-1/2" flange.
- None.**

ACCESSORIES:

- 16F.** Face operated opposed blade damper tack welded to rear of face plate. Requires 3/16" dia. hole for access to actuator.
- Other Options:** _____

Qty.	Listed Size		Accessory O.D.		Masonry Opening		Accessories	Damper	Mounting Option	Tag
	W	H	W	H	W	H				

To maintain KEES' policy of continuous product improvement, we reserve the right to change prices, specifications, ratings or dimensions without notice or obligation.

Project				Location			
Architect / Engineer				Dwg. No.	SEG-4P3w 03/15/05		KEES INCORPORATED 400 S. Industrial Dr. • P.O. Box L Elkhart Lake, WI 53020 Phone: (920) 876-3391 Fax: (920) 876-3065 Website: www.kees.com
Contractor							
Representative							