

# MODEL SDP — SECURITY CEILING DIFFUSER

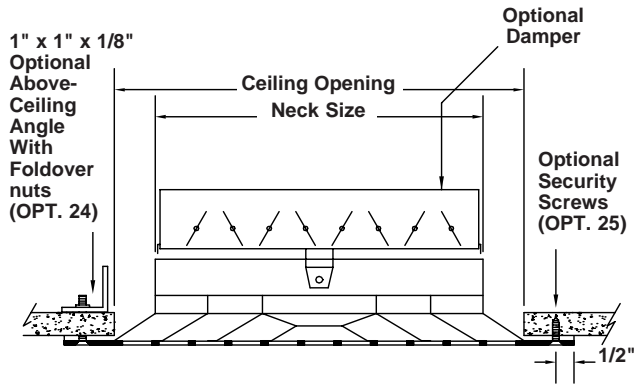
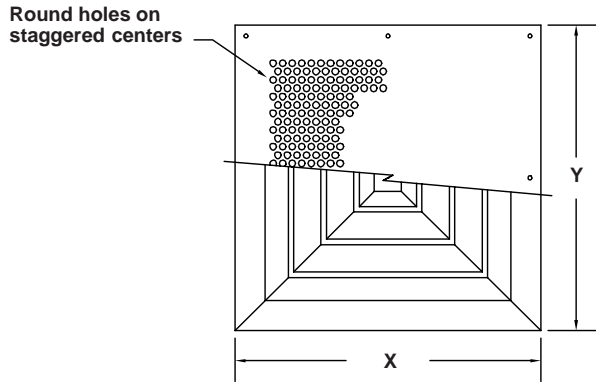

## STANDARD CONSTRUCTION

**Face:** 12 ga. steel.  
**Hole Pattern:** 5/16" round holes on 7/16" staggered centers.  
**Diffuser:** Commercial surface mount ceiling diffuser.  
 \*Neck sizes are available in 3" increments only.  
**Finish:** Two part polyurethane. White.

## REQUIRED CONSTRUCTION:

- Face Material:**
- 12 ga. steel (Std.)
  - 14 ga. steel
  - 10 ga. steel
  - Other \_\_\_\_\_
- Hole Pattern:**
- 5/16" round holes on 7/16" staggered centers (Std.)
  - 1/4" round holes on 7/16" staggered centers.
  - Other \_\_\_\_\_
- Finish:**
- White (Std.)
  - Other \_\_\_\_\_
- Other Material:**
- SDP-A** all aluminum construction. 10 ga. (.100") thick face, aluminum diffuser
  - SDP-SS** all stainless steel construction. 12 ga. type 304 face, stainless steel diffuser.

## MOUNTING OPTIONS:

- 25A.** (Std) Countersunk screw holes in face 10" o.c. with #10 x 2" long Torx security sheet metal screws. Clearance hole in diffuser for securing to structure above diffuser. Other screw style/size/length \_\_\_\_\_
- 25B.** Countersunk screw holes in face 10" o.c. with #10 x 1" long Torx security sheet metal screws. Starter hole in diffuser for securing face plate directly to diffuser. Other screw style/size/length \_\_\_\_\_
- 24.** Countersunk screw holes in face 10" o.c. with #10-24 x 2" long Torx security machine screws for 1-1/2" maximum ceiling thickness. 1" x 1" x 1/8" steel angle frame with matching holes and foldover nuts. Other screw style/size/length \_\_\_\_\_
- 11H.** 1" x 1" x 1/8" angle frame with extended legs on one end. Loose for field welding to sleeve (requires option SLV).

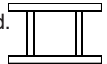

## ACCESSORIES:

- 16F.** Face operated opposed blade damper, loose for field installation.
- SXR.** Square to round transition, loose for field installation. Advise round size \_\_\_\_\_
- EG.** Equalizing grid, loose for field installation.
- SLV.** 12 ga. steel sleeve with continuously welded or formed seams, stitch welded to diffuser neck. Advise sleeve length \_\_\_\_\_
- Other Options:** \_\_\_\_\_

## THROW PATTERNS

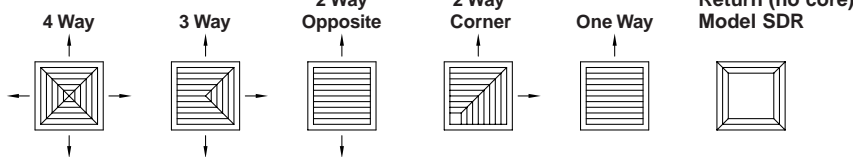

Qty.	Neck Size *	X x Y	Ceiling Opening	Throw Pattern	Accessories	Damper	Mounting Option	Tag

To maintain KEES' policy of continuous product improvement, we reserve KEES' right to change prices, specifications, ratings or dimensions without notice or obligation.

<b>Project</b>		<b>Location</b>		
<b>Architect / Engineer</b>		 <b>KEES INCORPORATED</b> 400 S. Industrial Dr. • P.O. Box L Elkhart Lake, WI 53020 Phone: (920) 876-3391 Fax: (920) 876-3065 Website: www.kees.com		
<b>Contractor</b>				<b>Dwg. No.</b>
<b>Representative</b>				<b>Date</b>

# MODEL SDPE SECURITY CEILING DIFFUSER WITH EXTENDED FACE PLATE

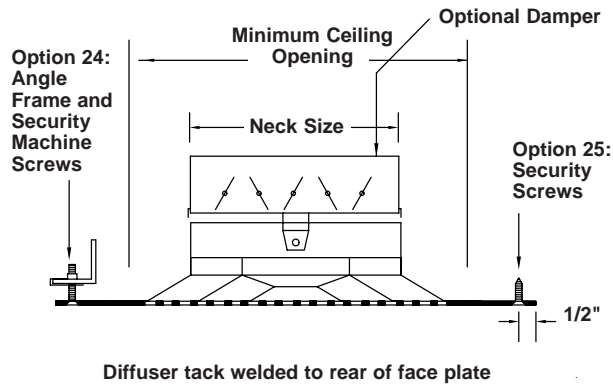
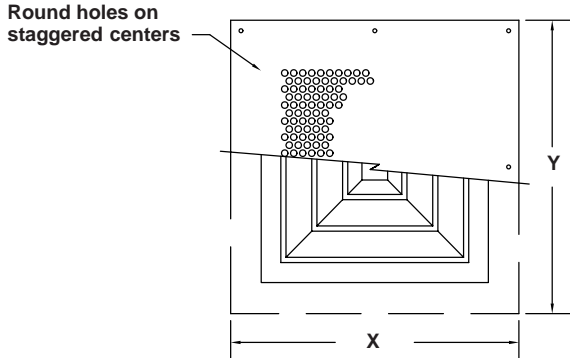

### STANDARD CONSTRUCTION

**Face:** 12 ga. steel.  
**Hole Pattern:** 5/16" round holes on 7/16" staggered centers.  
**Diffuser:** Commercial ceiling diffuser tack welded to rear of face plate.  
 \*Neck sizes are available in 3" increments only.  
**Finish:** Two part polyurethane. White.

### REQUIRED CONSTRUCTION:

- Face Material:**  12 ga. steel (Std.)  
 14 ga. steel  
 10 ga. steel  
 Other \_\_\_\_\_
- Hole Pattern:**  5/16" round holes on 7/16" staggered centers (Std.)  
 1/4" round holes on 7/16" staggered centers  
 Other \_\_\_\_\_
- Finish:**  White (Std.)  
 Other \_\_\_\_\_
- Other Material:**  **SDPE-A** all aluminum construction  
 10 ga. (.100") thick face, aluminum diffuser.
- SDPE-SS** all stainless steel construction  
 12 ga. type 304 face, stainless steel diffuser.

### MOUNTING OPTIONS:

- 25A.** (Std) Countersunk screw holes in perimeter of face 10" o.c. with #10 x 2" long Torx security sheet metal screws. Other screw style/size/length \_\_\_\_\_
- 24.** Countersunk screw holes in face 10" o.c. with #10-24 x 2" long Torx security machine screws for 1-1/2" maximum ceiling thickness. 1" x 1" x 1/8" steel angle frame with matching holes and foldover nuts. Other angle size \_\_\_\_\_ Other screw style/size/length \_\_\_\_\_

### ACCESSORIES:

- 16F.** Face operated opposed blade damper, loose for field installation.
- SXR.** Square to round transition, loose for field installation. Advise round size \_\_\_\_\_
- EG.** Equalizing grid, loose for field installation.
- Other Options:** \_\_\_\_\_

### THROW PATTERNS

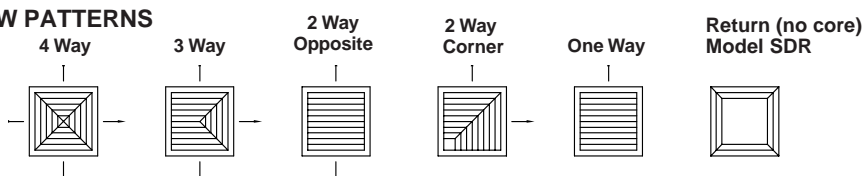

Qty.	Neck Size *	X x Y	Minimum Ceiling Opening	Throw Pattern	Accessories	Damper	Mounting Option	Tag

To maintain KEES' policy of continuous product improvement, we reserve the right to change prices, specifications, ratings or dimensions without notice or obligation.

<b>Project</b>		<b>Location</b>		 <p><b>KEES INCORPORATED</b>                  400 S. Industrial Dr. • P.O. Box L                  Elkhart Lake, WI 53020                  Phone: (920) 876-3391                  Fax: (920) 876-3065                  Website: www.kees.com</p>
<b>Architect / Engineer</b>		<b>Dwg. No.</b> SDPEw 03/29/05		
<b>Contractor</b>		<b>Date</b>		
<b>Representative</b>				

# MODEL SDPL SECURITY CEILING DIFFUSER FOR LAY-IN MOUNTING

Round holes on staggered centers

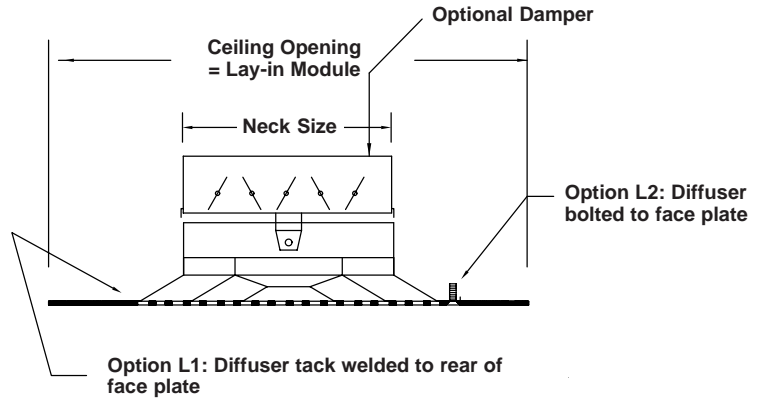
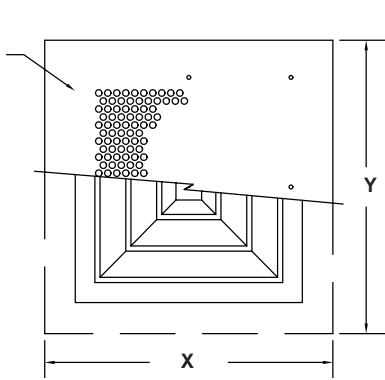

**STANDARD CONSTRUCTION**

**Face:** 12 ga. steel.  
**Hole Pattern:** 5/16" round holes on 7/16" staggered centers.  
**Diffuser:** Commercial ceiling diffuser.  
 \*Neck sizes are available in 3" increments only.  
**Finish:** Two part polyurethane. White.

**REQUIRED CONSTRUCTION:**

- Face Material:**  12 ga. steel (Std.)  
 14 ga. steel  
 10 ga. steel  
 Other \_\_\_\_\_
- Hole Pattern:**  5/16" round holes on 7/16" staggered centers (Std.)  
 1/4" round holes on 7/16" staggered centers  
 Other \_\_\_\_\_
- Finish:**  White (Std.)  
 Other \_\_\_\_\_
- Other Material:**  **SDPL-A** all aluminum construction  
 10 ga. (.100") thick face, aluminum diffuser.  
 **SDPL-SS** all stainless steel construction  
 12 ga. type 304 face, stainless steel diffuser.

**MOUNTING OPTIONS:**

- L1.** Diffuser tack welded to rear of face plate. (Std)
- L2.** Diffuser attaches to face plate with countersunk screw holes in face 10" o.c. and #10-24 x 1" long Torx security machine screws threaded into nuts on rear of face plate.  
 Other screw style/size/\_\_\_\_\_

**ACCESSORIES:**

- 16F.** Face operated opposed blade damper, loose for field installation.
- SXR.** Square to round transition, loose for field installation.  
 Advise round size \_\_\_\_\_
- EG.** Equalizing grid, loose for field installation.
- Other Options:** \_\_\_\_\_

**THROW PATTERNS**

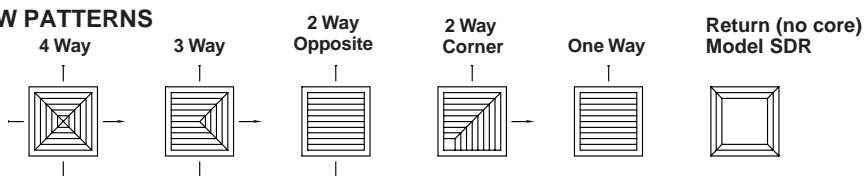

Qty.	Neck Size *	X x Y	Ceiling Grid Opening	Throw Pattern	Accessories	Damper	Mounting Option	Tag

To maintain KEESS' policy of continuous product improvement, we reserve the right to change prices, specifications, ratings or dimensions without notice or obligation.

<b>Project</b>		<b>Location</b>	
<b>Architect / Engineer</b>		<b>Contractor</b>	
<b>Representative</b>		<b>Dwg. No.</b>	<b>Date</b>
		SDPLw 03/29/06	



**KEES INCORPORATED**  
 400 S. Industrial Dr. • P.O. Box L  
 Elkhart Lake, WI 53020  
 Phone: (920) 876-3391  
 Fax: (920) 876-3065  
 Website: www.kees.com