

KSI-300T ISLAND HOOD

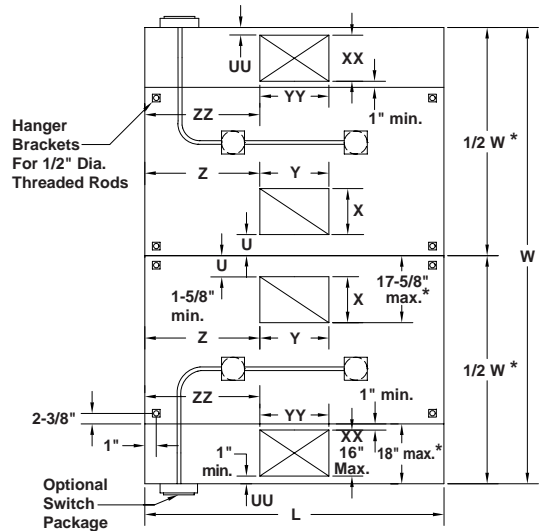
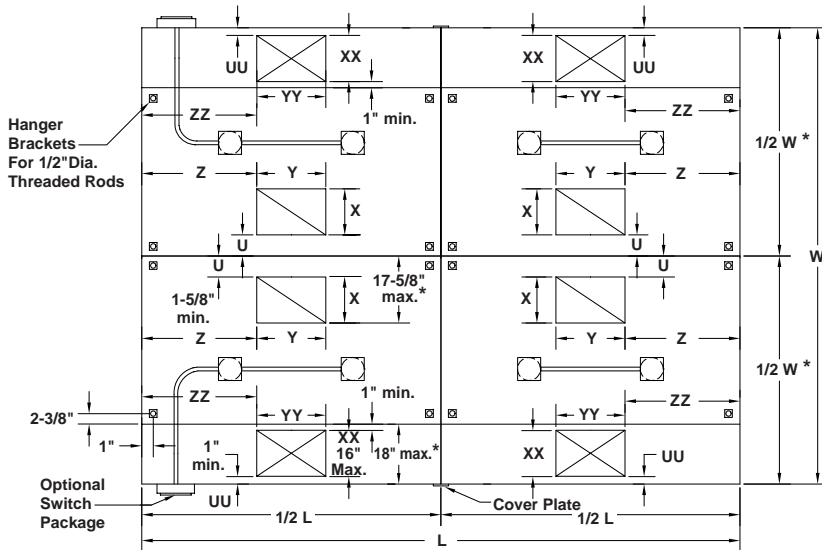
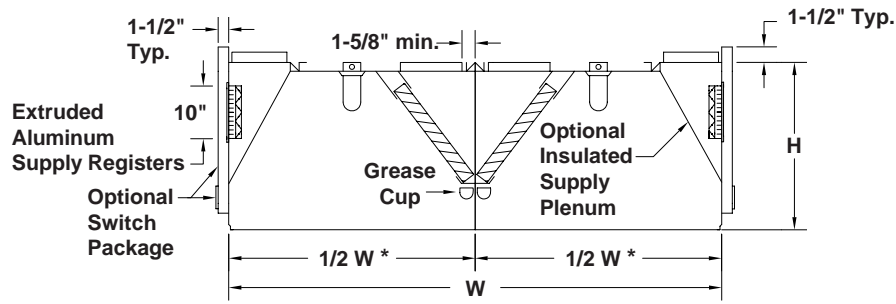

* IF HOOD WIDTH (1/2 W) LESS THAN 48" IS REQUIRED, CONTACT FACTORY FOR COLLAR DIMENSIONAL LIMITATIONS.

Quantity	① Material	② Gauge	Hood Dimensions			③ Number of Lights	④ Factory Cut Exhaust Opening *						
			L	W	H		U	X	Y	Z			

④ Factory Cut Supply Opening *				⑤ Filters				⑥ Finish	Other Options	Tag
UU	XX	YY	ZZ	Type	Material	Quantity	Size			

- ① Type 304 stainless steel.
- ② 18 ga. standard; other gauges available.
- ③ Standard is 100 watt vaporproof incandescent U.L. Listed for use on grease exhaust hood.
- ④ 2 sets of collars required on hood sections over 12' long.
- ⑤ Aluminum baffle type U.L. Classified filters standard.
- ⑥ #3 polish standard.
- ⑦ Optional exhaust air fire damper.
- ⑧ Optional supply air fire damper (not required by U.L.).
- ⑨ Optional supply air collar balancing damper.
- ⑩ Optional switch package with flush mounted stainless steel cover and junction box on top of hood. (Fan switch with illuminated toggle).
 - Hood mounted Loose for wall mounting
 - Number of light switches _____
 - Number of fan switches _____ Voltage _____ 115V _____ 24V
- ⑪ Optional insulated plenum.

UL US LISTED U.L. File MH12960 (Without Exhaust Fire Damper) U.L. File MH12071 (With Exhaust Fire Damper)



Project			Location		
Engineer			Dwg No.	SD-KSI-300T	
Architect			Date	03/07	
Contractor					
KEES INCORPORATED 400 S. Industrial Dr. • P.O. Box L Elkhart Lake, WI 53020 Phone: (920) 876-3391 Fax: (920) 876-3065 Website: www.kees.com					

To maintain KEES' policy of continuous product improvement, we reserve the right to change prices, specifications, ratings, or dimensions without prior notice or obligation.