



# KITCHEN EXHAUST DUCT ACCESS DOORS

Features:

- 14 GA. Welded Galvanized Steel Construction (Electro-Galvanized Frame, Galvanized Cover)
- Optional 16 GA. 304 S.S. Construction
- Finish - Mill
- Meets NFPA-96 Requirements For Use In Side Or Top Of Duct

## MODEL KEDA-A • SIDE / TOP OF DUCT INSTALLATION

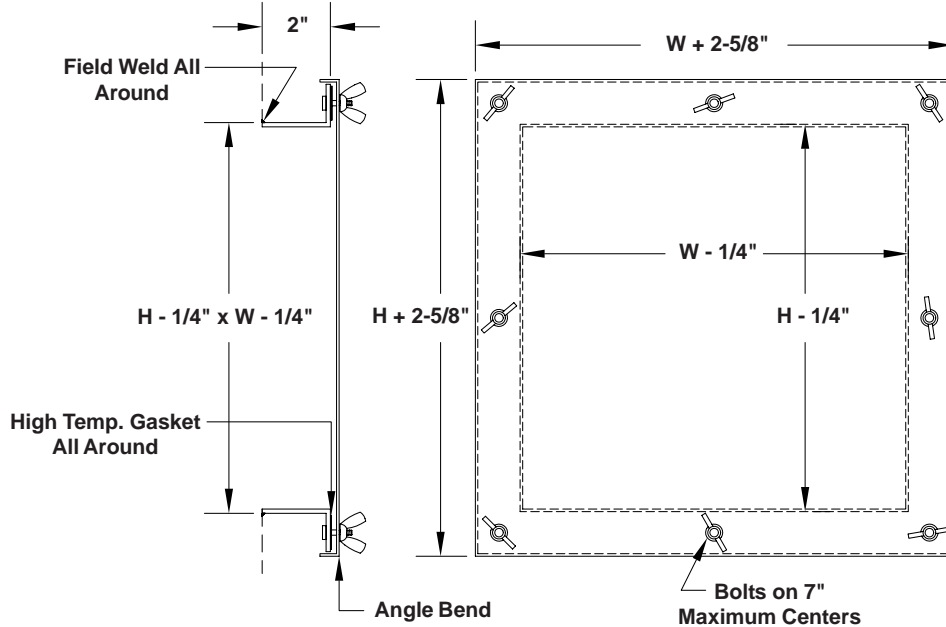

## MODEL KEDA-B • BOTTOM OF DUCT INSTALLATION

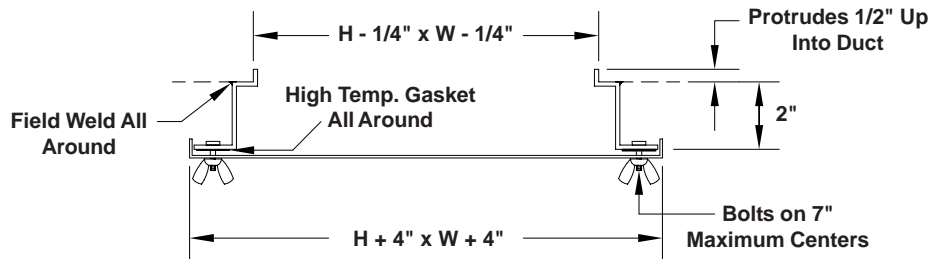

*NFPA-96 Requires Access Doors To Be Mounted On Side Or Top Of Duct*

Qty.	Model	W	H	Material		Finish	Options	Tag
				Steel	S.S.			
	KEDA-							
	KEDA-							
	KEDA-							
	KEDA-							

To maintain KEES' policy of continuous product improvement, we reserve the right to change prices, specifications, ratings or dimensions without notice or obligation.

<b>Project</b>		<b>Location</b>	
<b>Engineer</b>			
<b>Architect</b>		<b>Dwg. No.</b>	<b>SD-KEDA</b>
<b>Contractor</b>		<b>Date</b>	<b>05/07</b>



**KEES INCORPORATED**  
 400 S. Industrial Dr. • P.O. Box L  
 Elkhart Lake, WI 53020  
 Phone: (920) 876-3391  
 Fax: (920) 876-3065  
 Website: www.kees.com



# KITCHEN EXHAUST DUCT ACCESS DOORS

FOR USE ON ROUND DUCT

Features:

- 14 GA. Welded Galvanized Steel Construction (Electro-Galvanized Frame, Galvanized Cover)
- Optional 16 GA. 304 S.S. Construction
- Finish - Mill
- Meets NFPA-96 Requirements

## MODEL KEDA-R • SIDE / TOP OF DUCT INSTALLATION

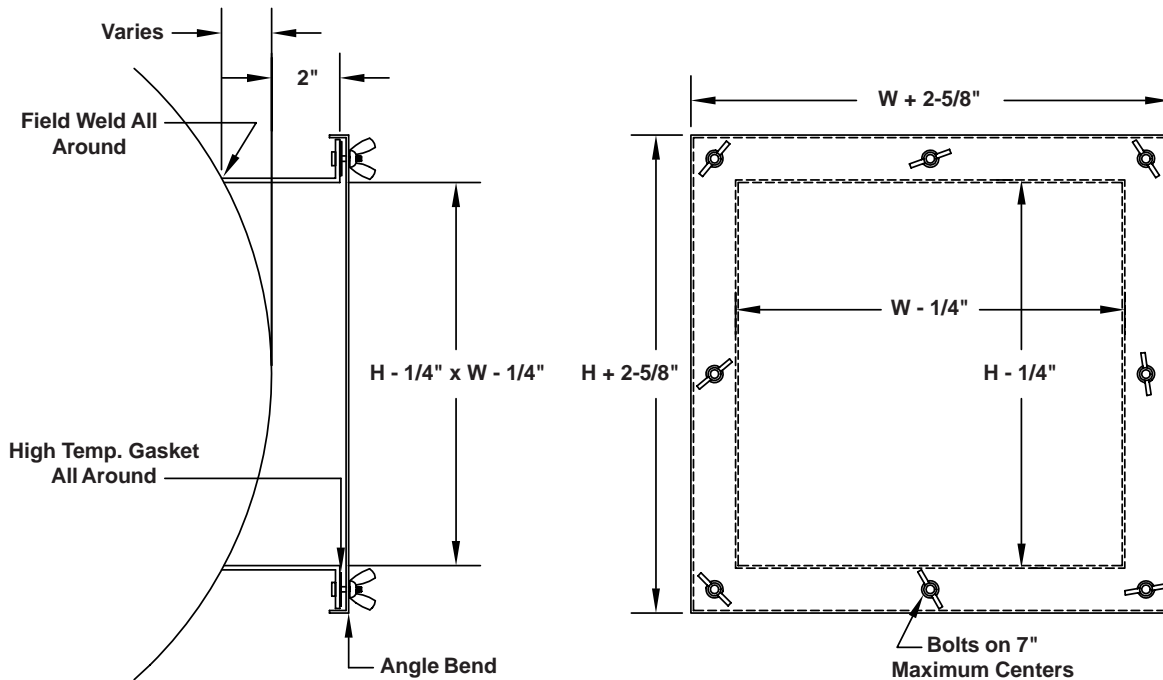

Qty.	W	H	Duct Dia.	Material		Finish	Options	Tag
				Steel	S.S.			

To maintain KEES' policy of continuous product improvement, we reserve the right to change prices, specifications, ratings or dimensions without notice or obligation.

<b>Project</b>				<b>Location</b>			
<b>Engineer</b>				<b>KEES INCORPORATED</b> 400 S. Industrial Dr. • P.O. Box L Elkhart Lake, WI 53020 Phone: (920) 876-3391 Fax: (920) 876-3065 Website: www.kees.com			
<b>Architect</b>							
		<b>Dwg. No.</b>	SD-KEDA-R				
<b>Contractor</b>			<b>Date</b>				