

MODEL KB DOUBLE ISLAND

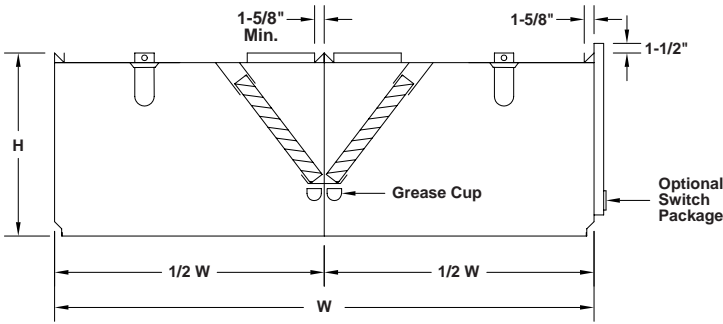

MODELS

Standard Model KB-DI

45° Pitch On Top Front Corners Model KB-DI-1

Lights In Recess Model KB-DI-3

Pitched Model KB-DI-P

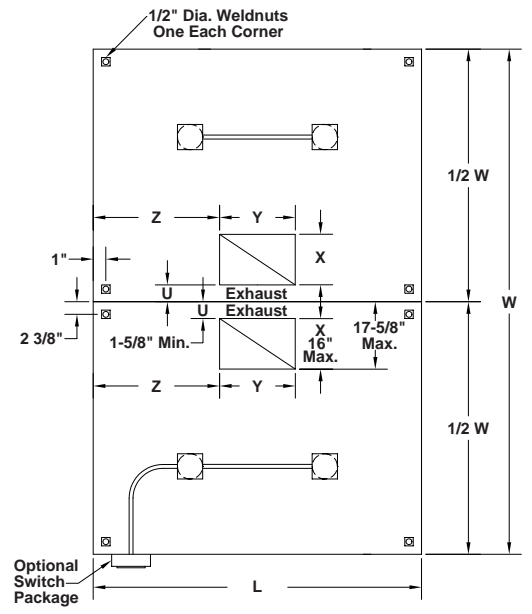
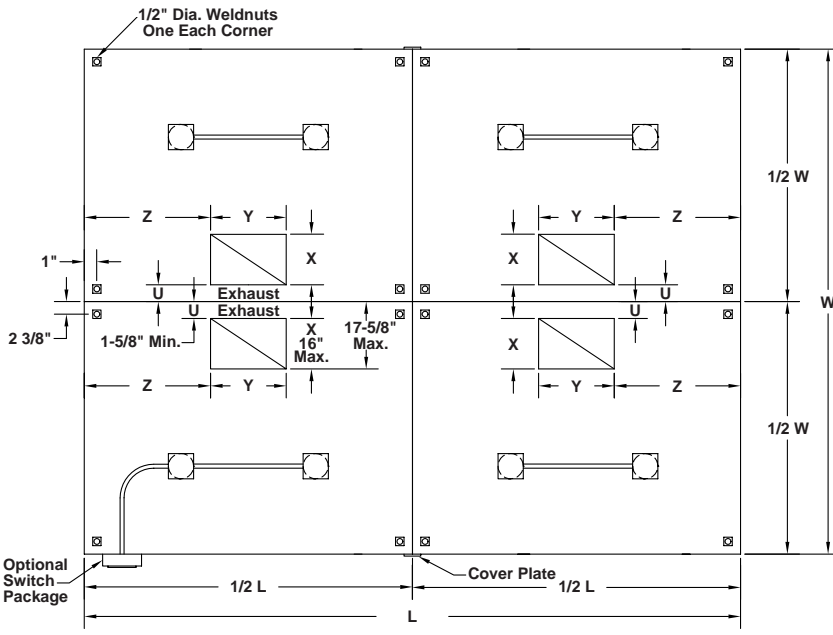
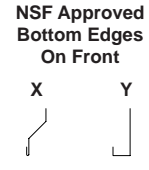

Quantity	Model	① Material	② Gauge	Hood Dimensions			③ Number of Lights	Bottom Edge Type
				L	W	H		

④ Factory Cut Opening				⑤ Filters				⑥ Finish	⑦ Side Skirts	Other Options	Tag
U	X	Y	Z	Type	Material	Qty.	Size				

- ① Type 304 stainless steel.
 - ② 18 ga. is standard; other gauges available.
 - ③ Standard is 100 watt vaporproof incandescent U.L. Listed for use on grease exhaust hood.
 - ④ 2 sets of collars required on hood sections over 12' long.
 - ⑤ Aluminum baffle type U.L. Classified filters standard.
 - ⑥ #3 polish standard.
 - ⑦ Advise if one or both sides. Make a sketch.
 - ⑧ Optional exhaust air fire damper.
 - ⑨ Optional switch package with surface mounted stainless steel cover and junction box on top of hood. (Fan switch with illuminated toggle).
- U.L. File MH12960 (Without Exhaust Fire Damper)
 U.L. File MH12071 (With Exhaust Fire Damper)
- Number of light switches _____
 Number of fan switches _____ Voltage _____ 115V _____ 24V



To maintain KEES' policy of continuous product improvement, we reserve the right to change prices, specifications, ratings or dimensions without notice or obligation.

Project		Location	
Engineer			
Architect		Dwg. No.	SD-KB-DI
Contractor		Date	02/09

KEES INCORPORATED
 400 S. Industrial Dr. • P.O. Box L
 Elkhart Lake, WI 53020
 Phone: (920) 876-3391
 Fax: (920) 876-3065
 Website: www.kees.com