

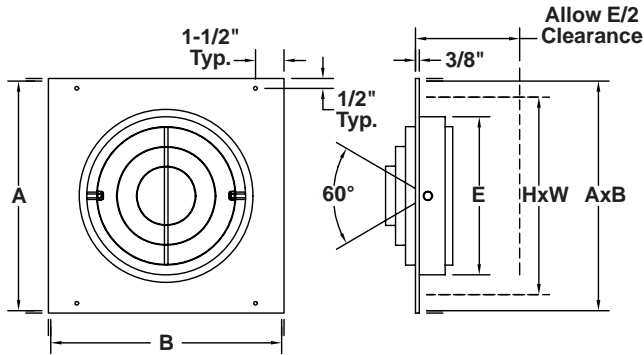

CONCENTRIC NOZZLE DIFFUSER - SQUARE OR RECTANGULAR PANEL



Available Standard Finishes:

- White Powder Coat
- Gloss Black Powder Coat
- Flat Black Powder Coat
- Silver Metallic Powder Coat
- Primer
- "Anodized" Powder Coat

Mounting:

- Mounting Screws Included

Material:

- Heavy Gauge Steel Construction

Options:

- Aluminum Construction
 - Clear Anodized Finish
 - White Powder Coat
 - Gloss Black Powder Coat
 - Flat Black Powder Coat
 - Silver Metallic Powder Coat
 - Primer
- Stainless Steel Construction
 - #304 S.S. / Matte Finish
 - #316 S.S. / Matte Finish

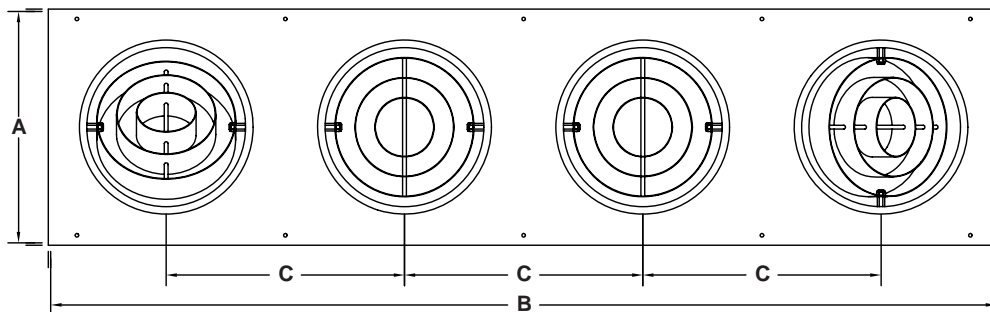
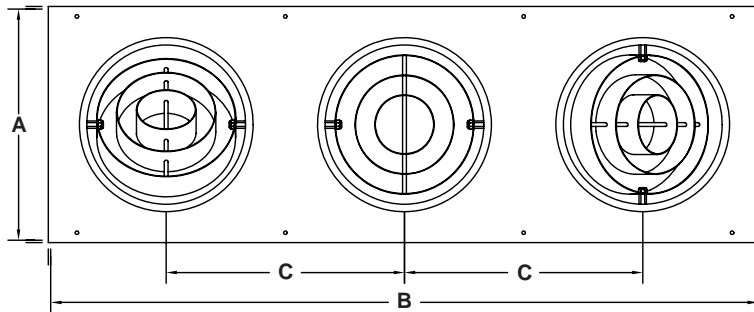
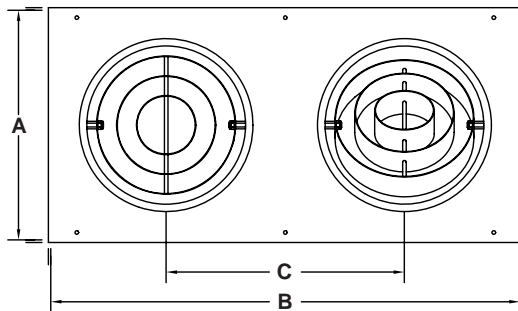

To maintain KEES' policy of continuous product improvement, we reserve the right to change prices, specifications, ratings or dimensions without notice or obligation.

Project		Location	
Engineer			
Architect		Dwg. No.	SD-CND
Contractor		Date	06/10



KEES INCORPORATED

400 S. Industrial Dr. • P.O. Box L
 Elkhart Lake, WI 53020
 Phone: (920) 876-3391
 Fax: (920) 876-3065
 Website: www.kees.com



CONCENTRIC NOZZLE DIFFUSER - SQUARE OR RECTANGULAR PANEL

Qty.	Model	E Element Dia.	Elements Per Panel	C Element Spacing	Rings Per Element	Panel Size		Duct Size		Finish	Tag
						A	B	H	W		
	CND-04-1	4	1	-	3	8	7-7/8	6	6		
	CND-04-2		2	6			14-7/8		12		
	CND-04-3		3	6			19-7/8		18		
	CND-04-4		4	6			25-7/8		24		
	CND-05-1	5	1	-	3	10	9-7/8	8	8		
	CND-05-2		2	8			17-7/8		16		
	CND-05-3		3	8			23-7/8		22		
	CND-05-4		4	8			31-7/8		30		
	CND-06-1	6	1	-	3	10	9-7/8	8	8		
	CND-06-2		2	9			18-7/8		17		
	CND-06-3		3	9			27-7/8		26		
	CND-06-4		4	9			36-7/8		35		
	CND-08-1	8	1	-	3	12	11-7/8	10	10		
	CND-08-2		2	12			23-7/8		22		
	CND-08-3		3	12			35-7/8		34		
	CND-08-4		4	12			47-7/8		46		
	CND-10-1	10	1	-	3	14	13-7/8	12	12		
	CND-10-2		2	13			26-7/8		25		
	CND-10-3		3	13			39-7/8		38		
	CND-10-4		4	13			52-7/8		51		
	CND-12-1	12	1	-	3	16	15-7/8	14	14		
	CND-12-2		2	15			30-7/8		29		
	CND-12-3		3	15			45-7/8		44		
	CND-12-4		4	15			60-7/8		59		
	CND-14-1	14	1	-	4	18	17-7/8	16	16		
	CND-14-2		2	17			34-7/8		33		
	CND-14-3		3	17			51-7/8		50		
	CND-14-4		4	17			68-7/8		67		
	CND-16-1	16	1	-	4	20	19-7/8	18	18		
	CND-16-2		2	20			39-7/8		38		
	CND-16-3		3	20			59-7/8		58		
	CND-16-4*		4	20			79-7/8		78		
	CND-18-1	18	1	-	4	22	21-7/8	20	20		
	CND-18-2		2	22			45-7/8		44		
	CND-18-3		3	22			66-7/8		64		
	CND-18-4*		4	22			89-7/8		88		
	CND-20-1	20	1	-	5	24	24	22	22		
	CND-22-1	22	1	-	5	26	26	24	24		
	CND-24-1	24	1	-	5	28	28	26	26		

*Unit shipped in two sections - assembly bolts provided.

To maintain KEES' policy of continuous product improvement, we reserve the right to change prices, specifications, ratings or dimensions without notice or obligation.

Project	Location	 KEES INCORPORATED 400 S. Industrial Dr. • P.O. Box L Elkhart Lake, WI 53020 Phone: (920) 876-3391 Fax: (920) 876-3065 Website: www.kees.com
Engineer		
Architect	Dwg. No. SD-CND	
Contractor	Date 06/10	



CONCENTRIC NOZZLE DIFFUSER - FOR USE ON ROUND DUCT

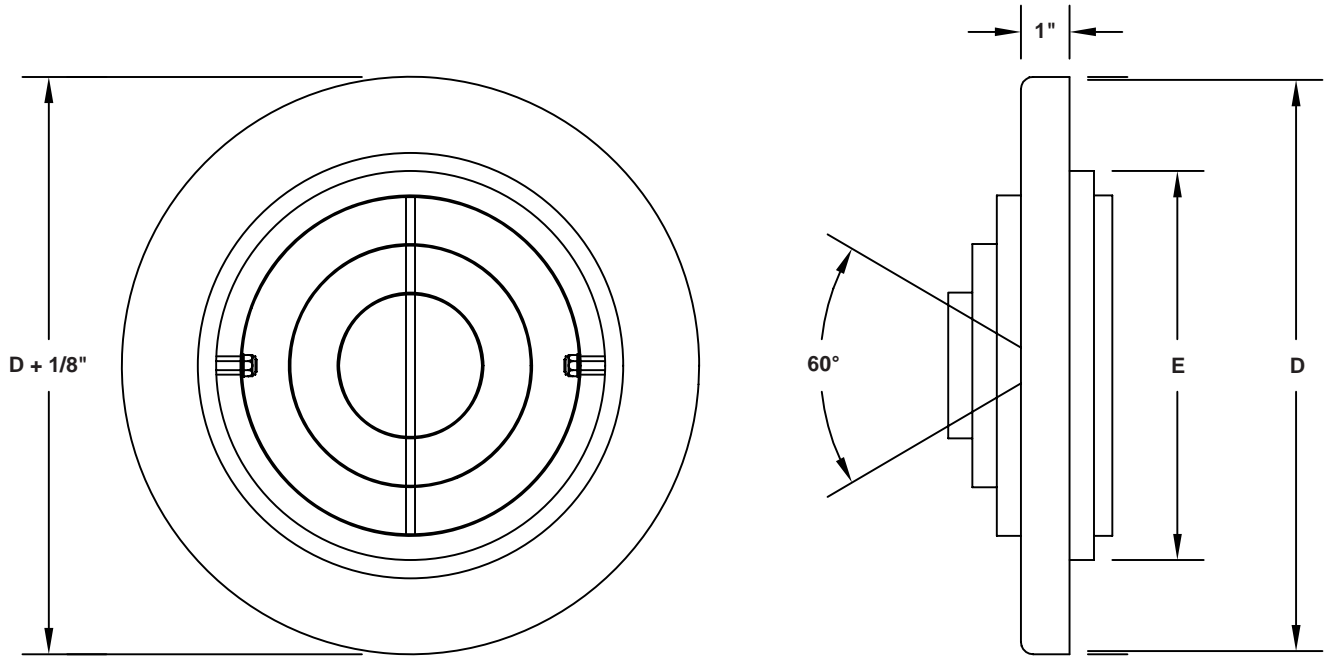

Available Standard Finishes:

- White Powder Coat
- Gloss Black Powder Coat
- Flat Black Powder Coat
- Silver Metallic Powder Coat
- Primer
- "Anodized" Powder Coat

Material:

- Heavy Gauge Steel Construction

Mounting:

- Mounting Fasteners Provided By Others

Options:

- Aluminum Construction
 - Clear Anodized Finish
 - Gloss Black Powder Coat
 - Flat Black Powder Coat
- Stainless Steel Construction
 - #304 S.S. / Matte Finish
 - #316 S.S. / Matte Finish
- White Powder Coat
- Silver Metallic Powder Coat
- Primer

Qty.	Model	E Element Dia.	Rings Per Element	D Duct Size	Finish	Tag
	CND-04-RD	4	3	6		
	CND-05-RD	5	3	6		
	CND-06-RD	6	3	8		
	CND-08-RD	8	3	10		
	CND-10-RD	10	3	12		
	CND-12-RD	12	3	14		
	CND-14-RD	14	4	16		
	CND-16-RD	16	4	18		
	CND-18-RD	18	4	20		
	CND-20-RD	20	5	22		
	CND-22-RD	22	5	24		
	CND-24-RD	24	5	26		

To maintain KEES' policy of continuous product improvement, we reserve the right to change prices, specifications, ratings or dimensions without notice or obligation.

Project		Location	
Engineer			
Architect		Dwg. No.	SD-CND-RD
Contractor		Date	06/10

KEES INCORPORATED
 400 S. Industrial Dr. • P.O. Box L
 Elkhart Lake, WI 53020
 Phone: (920) 876-3391
 Fax: (920) 876-3065
 Website: www.kees.com



CONCENTRIC NOZZLE DIFFUSER - ROUND PANEL

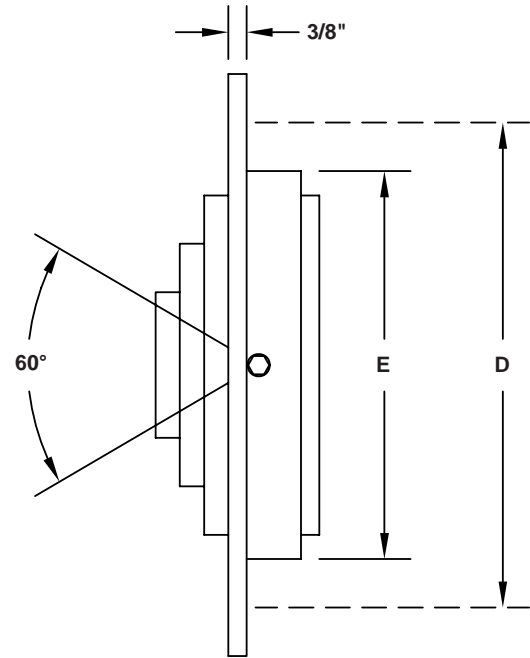
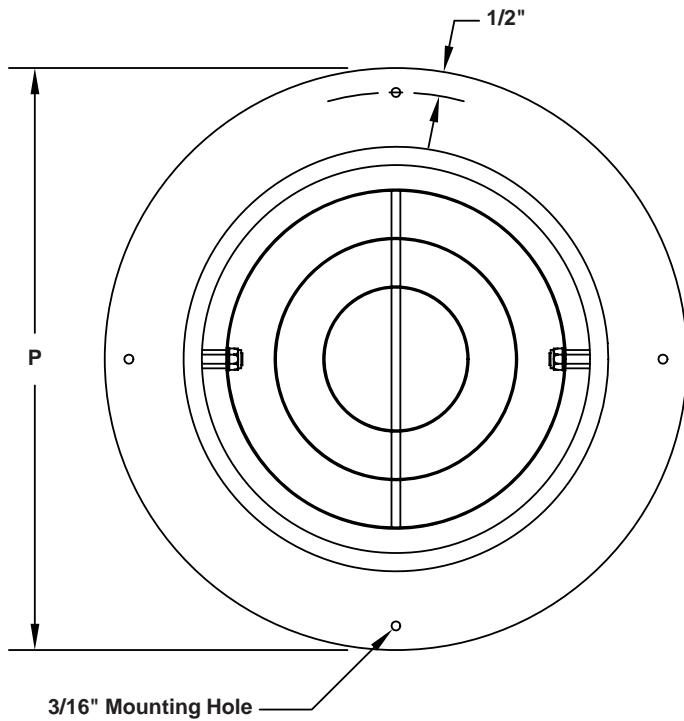

Available Standard Finishes:

- White Powder Coat
- Gloss Black Powder Coat
- Flat Black Powder Coat
- Silver Metallic Powder Coat
- Primer
- "Anodized" Powder Coat

Material:

- Heavy Gauge Steel Construction

Mounting:

- Mounting Screws Included

Options:

- Aluminum Construction
 - Clear Anodized Finish
 - Gloss Black Powder Coat
 - Flat Black Powder Coat
- Stainless Steel Construction
 - #304 S.S. / Matte Finish
 - #316 S.S. / Matte Finish
- White Powder Coat
- Silver Metallic Powder Coat
- Primer

Qty.	Model	E Element Dia.	Rings Per Element	D Duct Size	P Panel Size	Finish	Tag
	CND-04-RP	4	3	6	8		
	CND-05-RP	5	3	6	8		
	CND-06-RP	6	3	8	10		
	CND-08-RP	8	3	10	12		
	CND-10-RP	10	3	12	14		
	CND-12-RP	12	3	14	16		
	CND-14-RP	14	4	16	18		
	CND-16-RP	16	4	18	20		
	CND-18-RP	18	4	20	22		
	CND-20-RP	20	5	22	24		
	CND-22-RP	22	5	24	26		
	CND-24-RP	24	5	26	28		

To maintain KEES' policy of continuous product improvement, we reserve the right to change prices, specifications, ratings or dimensions without notice or obligation.

Project		Location	
Engineer			
Architect		Dwg. No.	SD-CND-RP
Contractor		Date	06/10



KEES INCORPORATED
 400 S. Industrial Dr. • P.O. Box L
 Elkhart Lake, WI 53020
 Phone: (920) 876-3391
 Fax: (920) 876-3065
 Website: www.kees.com



CONCENTRIC NOZZLE DIFFUSER - LAY-IN PANEL

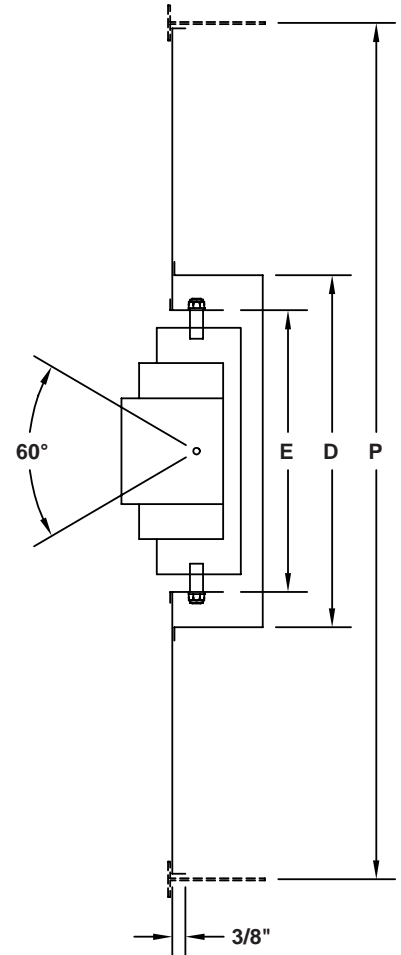
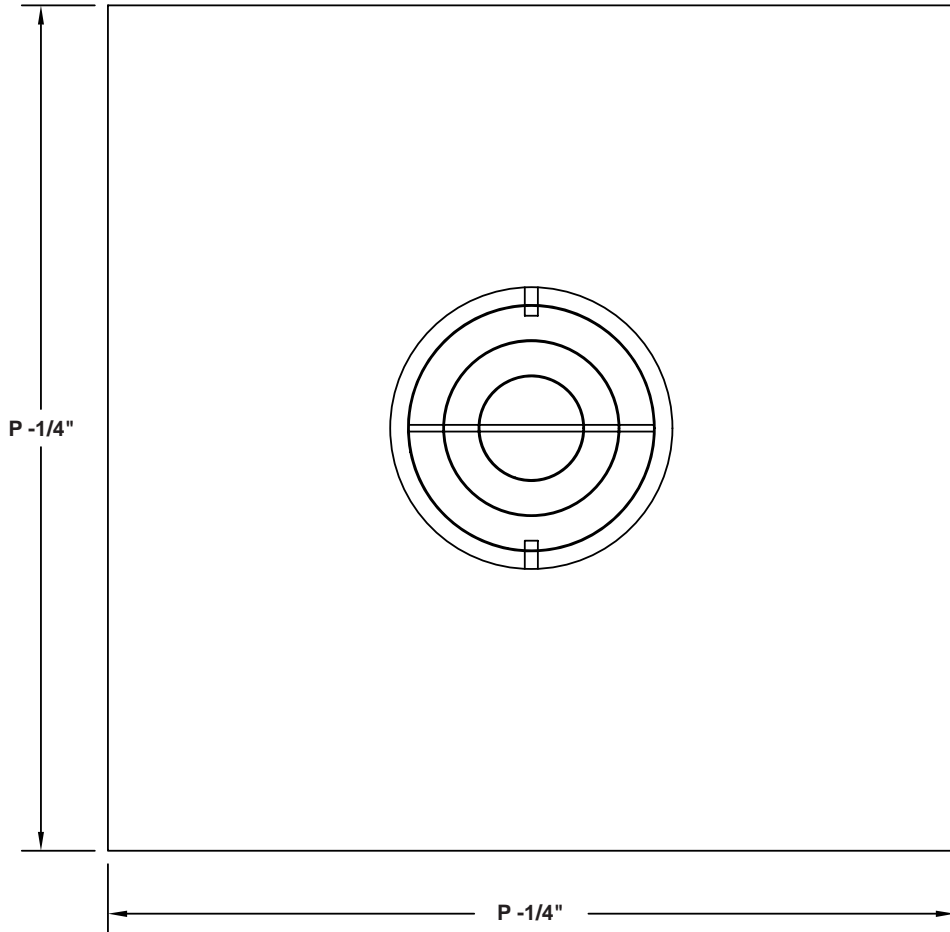

Available Standard Finishes:

- White Powder Coat
- Gloss Black Powder Coat
- Flat Black Powder Coat
- Silver Metallic Powder Coat
- Primer
- "Anodized" Powder Coat

Material:

- Heavy Gauge Steel Construction

Options:

- Aluminum Construction
 - Clear Anodized Finish
 - Gloss Black Powder Coat
 - Flat Black Powder Coat
- Stainless Steel Construction
 - #304 S.S. / Matte Finish
 - #316 S.S. / Matte Finish

- White Powder Coat
- Silver Metallic Powder Coat
- Primer

Qty.	Model	E Element Dia.	Rings Per Element	D Duct Size	P Panel Size	Finish	Tag
	CND-06-LI	6	3	8	24		
	CND-08-LI	8	3	10	24		
	CND-10-LI	10	3	12	24		
	CND-12-LI	12	3	14	24		
	CND-14-LI	14	4	16	24		

To maintain KEES' policy of continuous product improvement, we reserve the right to change prices, specifications, ratings or dimensions without notice or obligation.

Project		Location	
Engineer			
Architect		Dwg. No.	SD-CND-LI
Contractor		Date	06/10



KEES INCORPORATED
 400 S. Industrial Dr. • P.O. Box L
 Elkhart Lake, WI 53020
 Phone: (920) 876-3391
 Fax: (920) 876-3065
 Website: www.kees.com