

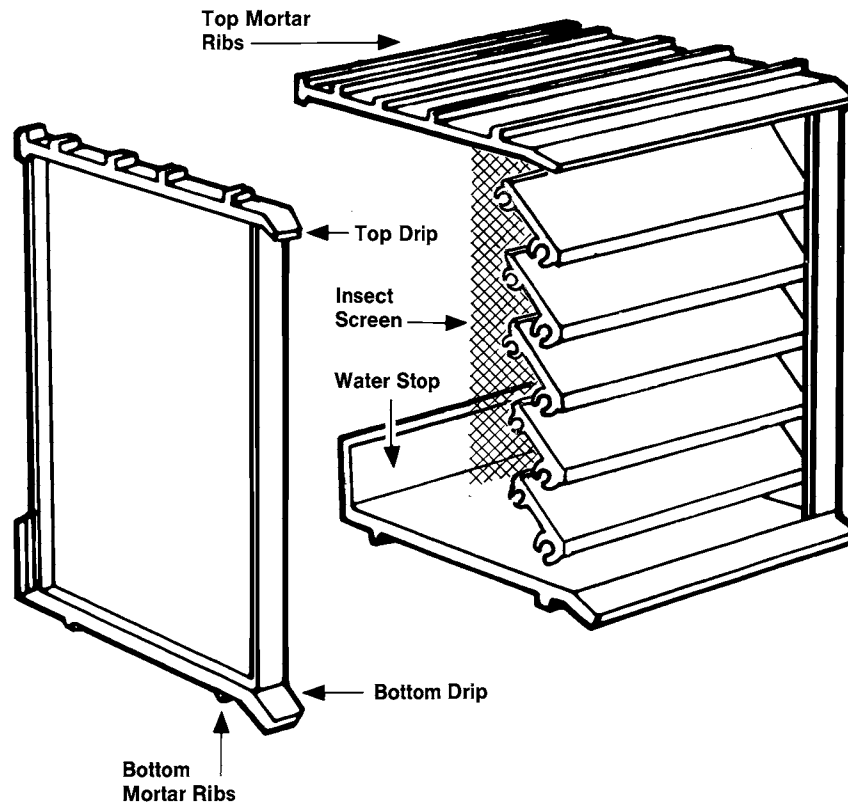

EXTRUDED ALUMINUM BRICK VENT



- All 6063T5 extruded sections
- Minimum .125" thickness
- 204-R1 clear anodized finish
- Continuous seepage on bottom
- Overlapping blades
 - Extruded blades with storm lip
 - All blades at 45 degrees
 - Aluminum insect screen (18 x 14 mesh)
 - Extruded stop for screen retention
 - Masonry grip at top and bottom
 - Available with flanged frame

EXTRUDED ALUMINUM BRICK VENT - MODEL BV

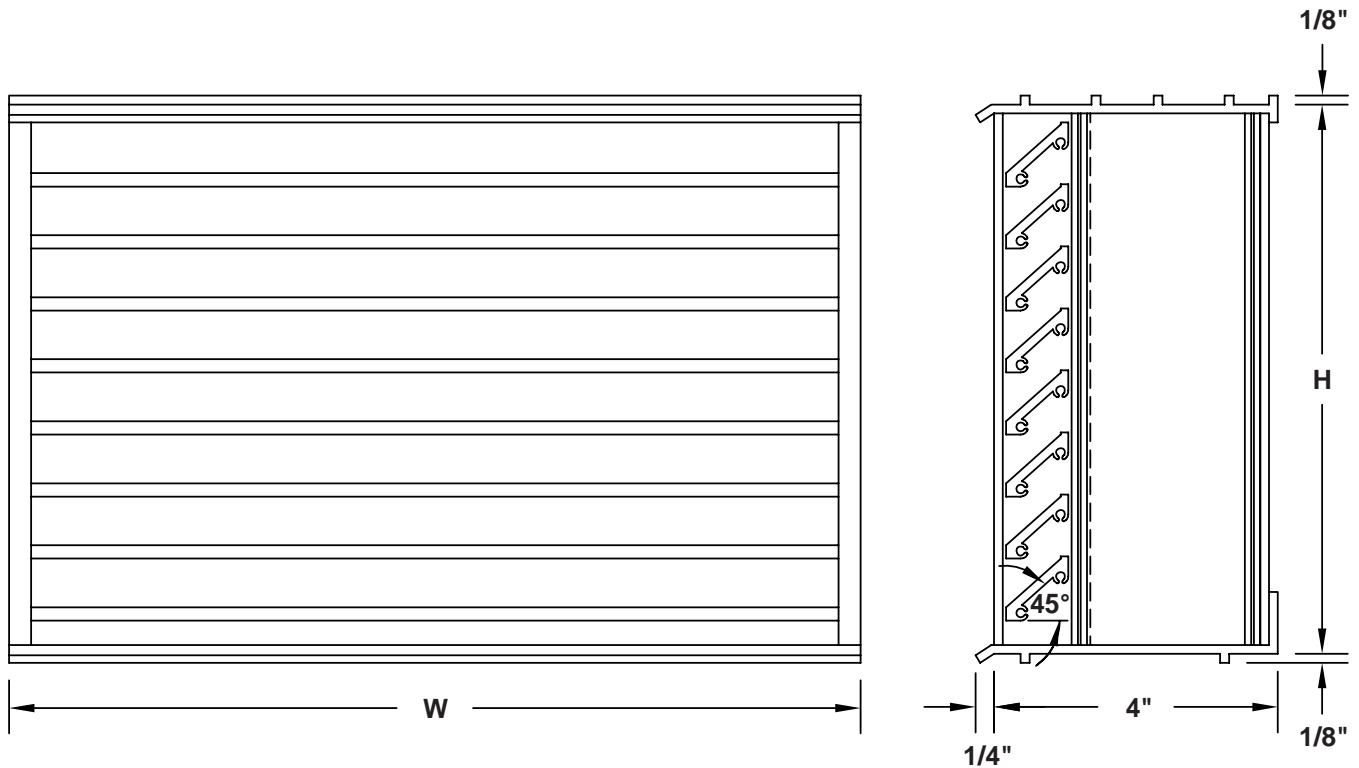

STANDARD CONSTRUCTION

.125" Minimum 6063T5 Extruded Aluminum
 204-R1 Clear Anodized Finish
 Aluminum Insect Screen, 18 x 14 Mesh

Quantity	Model	Size		Tag
		W	H	
	BV0808	8.125"	7.75"	
	BV1208	12.0"	7.75"	
	BV1508	15.625"	7.75"	
	BV1608	16.5"	7.75"	
	BV2408	24.0"	7.75"	
	BV3208	32.0"	7.75"	
	BV4808	48.0"	7.75"	

NOTE: Brick vents are available in other standard heights:
 2-3/8", 4-3/4", 11-3/4" and 15-3/4".
 Flanged brick vents are also available. Specify Model BVFL.

To maintain KEES' policy of continuous product improvement, we reserve the right to change prices, specifications, ratings or dimensions without notice or obligation.

Project		Location		
Engineer		 KEES INCORPORATED 400 S. Industrial Dr. Elkhart Lake, WI 53020 Phone: (920) 876-3391 Fax: (920) 876-3065 Website: www.kees.com		
Architect			Dwg. No.	SD-BV
Contractor			Date	06/07