

# AIR DISTRIBUTION PLENUMS – MODEL ADP

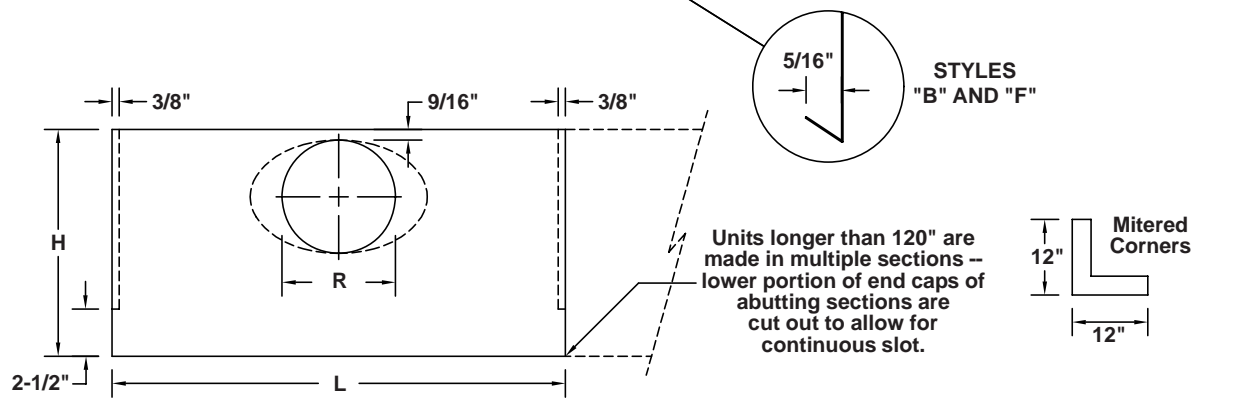
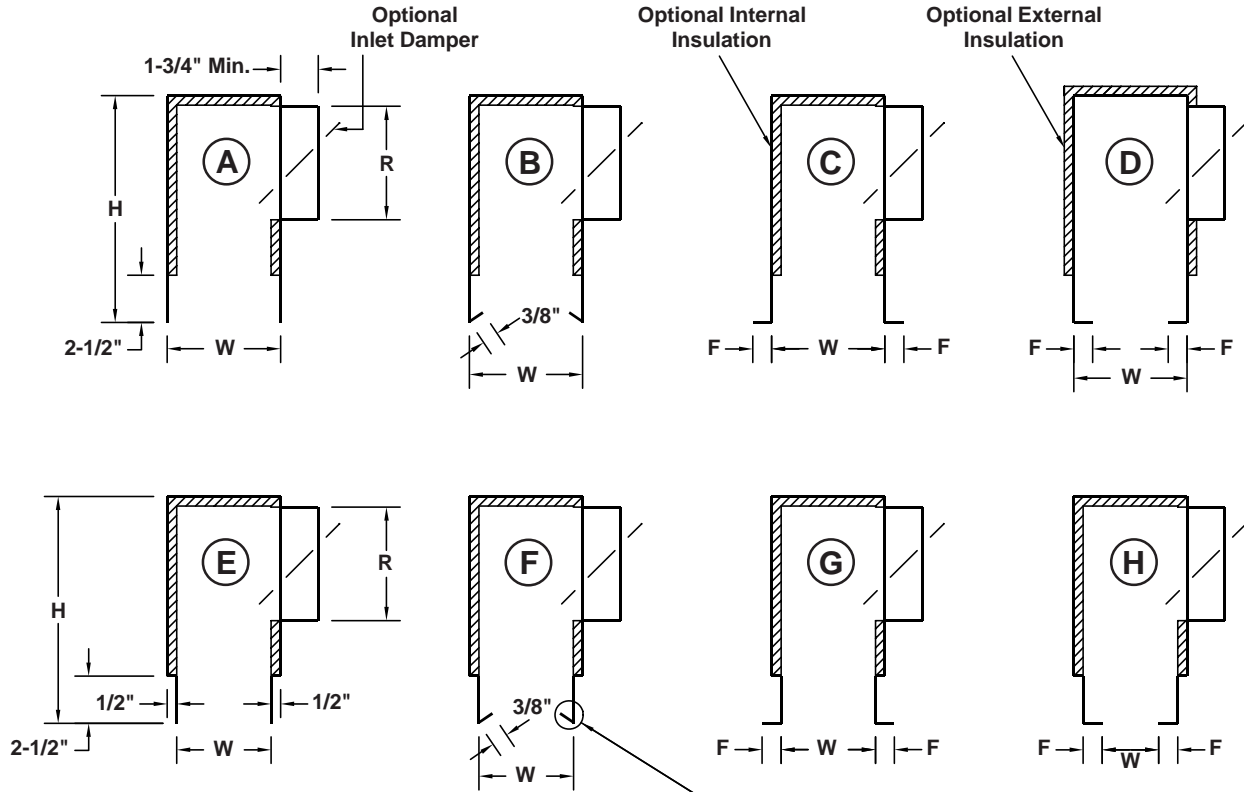

**Material:** 24 ga. galvanized.  
**Insulation:** 1/2" standard. Other thicknesses available.  
**Lengths:** Any through 120" in one piece. Unlimited continuous length.  
**Inlets:** All sizes. Oval inlets available at an extra charge.  
**Widths:** 1/2" minimum - no limit on maximum. All sizes in between.

Qty.	Model	Insulation		L	W	H	R	F	Damper	Special	Tag
		Internal	External								

To maintain KEES' policy of continuous product improvement, we reserve the right to change prices, specifications, ratings or dimensions without notice or obligation.

<b>Project</b>		<b>Location</b>				
<b>Engineer</b>						 <b>KEES INCORPORATED</b> 400 S. Industrial Dr. • P.O. Box L Elkhart Lake, WI 53020 Phone: (920) 876-3391 Fax: (920) 876-3065 Website: www.kees.com
<b>Architect</b>		<b>Dwg. No.</b>	<b>SD-ADP</b>			
<b>Contractor</b>		<b>Date</b>	<b>06/07</b>			