

CUSTOM AIR CABINET

AVAILABLE GRILLE BAR STYLES

BAR SPACING	BAR WIDTH	DEFLECTION
1/2"	1/4"	0 Degrees
1/2"	1/4"	15 Degrees
1/2"	1/8"	30 Degrees
1/2"	1/8"	0 Degrees
1/2"	1/8"	15 Degrees
1/4"	1/8"	0 Degrees
1/4"	1/8"	15 Degrees

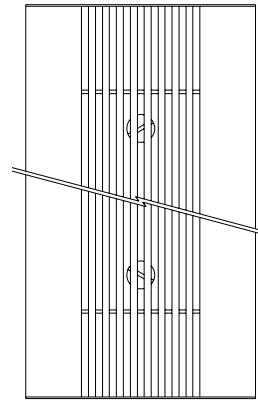

PLAN VIEW

CONSTRUCTION: Easily adjustable damper provides an even air discharge along the entire length of the cabinet as well as air quantity control. A flush bar grille and flush butt joints provide a totally clean installation. Grille of extruded aluminum in clear anodized finish available in 0, 15 or 30 degrees, 2-1/2 inches less in width than cabinet.

AVAILABLE FINISHES: Primer, stock or custom color enamels.

OTHER OPTIONS: Insulation, debris screen.

INSIDE / OUTSIDE CORNER

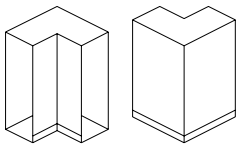

- Use for transfer of air around 90° inside (IC) or outside(OC) corners

END CAP

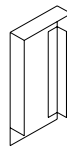

- Use to terminate run
- Integral with top/front
- Standard on both ends

WALL TRIMMER

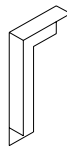

- Use to trim at intersecting walls
- *Designate left or right*

1-1/2" Minimum 1" Minimum

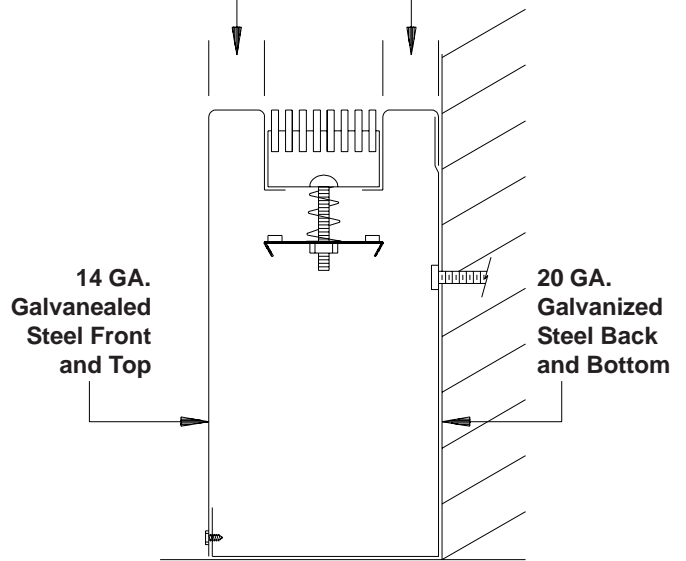

SIDE VIEW

Qty.	Length	No. of Sections	Cabinet Height	Cabinet Width	Grille Width	Gauge Steel	Cabinet Finish	Grille Finish	Tag

To maintain KEES' policy of continuous product improvement, we reserve the right to change prices, specifications, ratings or dimensions without notice or obligation.

Project		Location		 KEES INCORPORATED 400 S. Industrial Dr. • P.O. Box L Elkhart Lake, WI 53020 Phone: (920) 876-3391 Fax: (920) 876-3065 Website: www.kees.com
Engineer				
Architect		Dwg. No.	AC	
Contractor		Date	02-02	